

# ENGINEERING DESIGN STANDARDS

January 6, 2021

City of Auburn  
Community Development & Public Works Departments  
25 West Main Street  
Auburn, WA 98001-4998

**Approved By:**

---

Jacob Sweeting, P.E.  
Assistant Director of Engineering Services/City Engineer

01/12/2021

---

Date

## TABLE OF CONTENTS

1	General Information.....	11
1.00	Preface .....	11
1.01	Definitions .....	11
1.02	Contact Information.....	18
1.03	City Reference Material .....	18
1.03.01	City of Auburn Surface Water Management Manual (SWMM).....	18
1.03.02	City of Auburn Engineering Construction Standards Manual .....	18
1.03.03	Planning Documents.....	19
1.03.04	Informational Handouts .....	19
1.03.05	Additional Technical Information.....	19
1.03.06	Other Reference Material .....	19
1.04	Deviation from Standards .....	20
1.04.01	General Deviations.....	20
1.04.02	Surface Water Management Manual (SWMM) Deviations .....	21
1.05	Appeal of City Engineer’s Decision.....	21
1.06	Changes to Standards.....	21
1.07	Downtown Sidewalk Design Guidelines.....	22
1.07.01	Applicability.....	22
1.07.02	Downtown Sidewalks .....	23
1.07.03	Street Corners .....	24
1.07.04	Street Trees in Grates.....	25
1.07.05	Pedestrian Crosswalks.....	25
1.07.06	Lighting and Traffic Signals.....	26
2	Plan Approval Process.....	27
2.00	Preface .....	27
2.01	Types of Plans.....	27
2.01.01	Grading Plans .....	27
2.01.02	Building Site Plans .....	27
2.01.03	Public Facility Extension (FAC) Plans .....	27
2.01.04	Other Plans.....	27

2.02	Review and Approval Process .....	28
2.02.01	Submittals.....	28
2.02.02	City Review .....	29
2.02.03	Plan Approval .....	29
2.02.04	Project Close Out.....	30
3	Plan Preparation Requirements.....	32
3.00	Preface .....	32
3.01	General Requirements .....	32
3.02	Plan Format .....	32
3.03	General Plan Requirements .....	34
3.03.01	Standard Plan Format.....	34
3.03.02	Drafting Standards .....	34
3.04	Plan Sheet Elements.....	35
3.04.01	Cover Sheet .....	35
3.04.02	Temporary Erosion and Sediment Control (TESC) Plan Sheet .....	36
3.04.03	Grading and Private Storm Drainage Plan Sheet .....	37
3.04.04	Cross-Section Sheet.....	38
3.04.05	Detail Sheet .....	38
3.04.06	Public Storm Drainage Plan Sheet.....	39
3.04.07	Utility Plan Sheets .....	40
3.04.08	Utility Profile Sheet .....	42
3.04.09	Public Street Plan and Profile Sheet.....	43
3.04.10	Site and Landscape Plan Sheet.....	49
3.04.11	Site Irrigation Plan sheet .....	50
3.04.12	Critical Area Restoration/Mitigation .....	50
3.04.13	Phasing Plans.....	50
	Appendix A – Approval Blocks .....	52
	Appendix B – Standard Notes .....	53
	Appendix C – Deviations .....	58
	Appendix D – Survey Standards.....	59
	Appendix E – Minor Grading Permit Criteria .....	61
	Appendix F – AutoCAD Layers Standards.....	62

4	Report Preparation Requirements.....	64
4.00	Preface .....	64
4.01	General Requirements .....	64
4.02	Report Types and Requirements.....	64
4.02.01	Geotechnical Reports .....	64
4.02.02	Stormwater Site Plan Report.....	65
4.02.03	Critical Area Report .....	65
4.02.04	Traffic Impact Analysis .....	66
4.02.05	Construction Stormwater Pollution Prevention Plan (SWPPP).....	66
4.02.06	Other Reports.....	66
5	TESC, Clearing and Grading .....	67
5.00	Preface .....	67
5.01	TESC Design Criteria .....	67
5.01.01	Temporary Erosion and Sediment Control (TESC) .....	67
5.01.02	Temporary Sedimentation Systems .....	67
5.01.03	Construction SWPPP .....	67
5.02	Land Clearing.....	67
5.03	Grading.....	67
5.03.01	Purpose .....	67
5.03.02	Excavations.....	68
5.03.03	Fills.....	68
5.04	Retaining Walls.....	69
5.04.01	Underdrains.....	69
5.04.02	Rock Walls .....	70
5.04.03	Block Retaining Walls .....	70
5.04.04	Reinforced Concrete Walls.....	70
5.04.05	Mechanically Stabilized Earth Walls (MSE Walls) .....	70
5.05	Construction Sequence .....	71
5.05.01	Requirements.....	71
6	Storm Drainage Facilities.....	72
6.00	Preface .....	72
6.01	SWMM Requirements.....	72

6.02	Additional Requirements .....	74
6.02.01	Storm Drainage Pipes and Structures .....	74
7	Water Facilities.....	75
7.00	Preface .....	75
7.01	Water Mains.....	75
7.01.01	Water Main Sizing .....	75
7.01.02	Water Main Location.....	76
7.01.03	Water Main Fittings.....	76
7.02	Water Services .....	77
7.02.01	Domestic Services.....	77
7.02.02	Other Services .....	78
7.03	Water Valves .....	79
7.03.01	Water Valve Sizing .....	79
7.03.02	Water Valve Location.....	79
7.04	Cross Connection Control.....	79
7.04.01	Domestic Services .....	80
7.04.02	Irrigation Services.....	80
7.04.03	Fire Line Connections .....	80
7.04.04	General .....	80
7.05	Pressure Reducing Stations.....	81
7.06	Fire Systems .....	81
7.06.01	Fire Hydrant Assemblies.....	81
7.06.02	Fire Sprinkler Systems .....	82
7.06.03	Fire Flows.....	83
7.06.04	Fire Authority and Hydrant Access.....	84
7.07	Public Water Utility Easements.....	84
8	Sanitary Sewer Facilities.....	85
8.00	Preface .....	85
8.01	Sanitary Sewer Mains.....	85
8.01.01	Sanitary Sewer Main Sizing/Slope.....	85
8.01.02	Sanitary Sewer Main Location.....	86
8.01.03	Material Requirements for Sanitary Sewer Systems .....	87

8.02	Sanitary Sewer Manholes.....	88
8.02.01	Sanitary Sewer Manhole Type and Size .....	88
8.02.02	Sanitary Sewer Manhole Locations.....	89
8.02.03	Sanitary Sewer Manhole Parameters.....	90
8.03	Side Sewers .....	90
8.04	Oil/Water Separators .....	92
8.05	Pressurized Sewer Systems .....	93
8.06	Sanitary Sewer Meters .....	93
8.07	Public Sanitary Sewer Utility Easements.....	94
9	Facilities in the Right of Way .....	95
9.0	Preface .....	95
9.01	Franchise/Public Way Agreement Requirement.....	95
9.02	Construction Permit Requirement .....	95
9.03	Underground Facilities .....	95
9.03.01	Design Criteria.....	95
9.03.02	Perpendicular Asphalt Trenching and Restoration Requirements .....	96
9.03.03	Longitudinal Trenching in Asphalt Pavement .....	97
9.03.04	Trenching in Cement Concrete Pavement .....	98
9.03.05	Trenching in Other Right-of-Way Surfaces .....	98
9.04	Aboveground Facilities .....	98
9.05	Building and Structure Related Facilities .....	99
9.06	Small Wireless Facilities .....	99
9.06.01	General Requirements .....	99
9.06.02	Attachments to City Facilities.....	100
9.06.03	General Pole Requirements .....	100
9.06.04	Wiring and Conduit .....	101
9.06.05	Concealment .....	101
9.06.06	Pole Mounted Antennas and Equipment.....	101
9.06.07	Non-Pole Mounted Equipment.....	102
9.06.08	Strand Mounted Small Wireless Facilities.....	102
10	Streets .....	103
10.00	Required Public Street Improvements .....	103

10.00.01	Half-Street Improvements.....	103
10.00.02	Additional Improvements.....	104
10.01	Street Classification and Street Layout .....	104
10.01.01	Arterials .....	105
10.01.02	Collectors.....	108
10.01.03	Local Streets .....	110
10.01.04	Alleys .....	115
10.01.05	Private Access Roads on Access Tracts or Easements (Shared Driveways) ..	116
10.01.06	Private Street.....	117
10.01.07	Cul-de-sacs.....	118
10.02	Street Geometry.....	118
10.02.01	Horizontal Curves .....	118
10.02.02	Reverse Curves .....	119
10.02.03	Superelevations.....	119
10.02.04	Vertical Grades.....	119
10.02.05	Vertical Curves .....	119
10.02.06	Cross Slopes.....	119
10.02.07	Posted and Design Speed .....	120
10.02.08	Right of Way.....	120
10.02.09	Sight Distance.....	120
10.03	Roadway Width (Travel Way).....	121
10.03.01	Inside Through Lanes and Curb Lanes.....	121
10.03.02	Center Turn Lanes .....	121
10.03.03	Other Lanes .....	121
10.03.04	Road Edge.....	122
10.03.05	On-Street Parking .....	122
10.04	Roadway Intersections.....	123
10.04.01	Intersection Spacing .....	123
10.04.02	Horizontal Approach Angle .....	124
10.04.03	Intersection Approach Offsets .....	124
10.04.04	Curb and Right-of-Way Radius .....	124
10.04.05	Landing Approach.....	124

10.05	Driveways .....	125
10.05.01	Driveway Classifications .....	125
10.05.02	Driveway Locations .....	126
10.05.03	Driveway Lay Out.....	128
10.05.04	Driveway Alignment (Horizontal and Vertical).....	129
10.05.05	Driveway Widths .....	129
10.05.06	Restricted Access Driveways .....	129
10.06	Sidewalks.....	129
10.06.01	Sidewalk Widths .....	130
10.06.02	Meandering Sidewalks .....	130
10.06.03	Accessibility .....	130
10.06.04	Curb Ramps .....	130
10.07	Bikeways.....	131
10.07.01	Class I Bikeway .....	131
10.07.02	Class II Bikeway .....	131
10.07.03	Class III Bikeway .....	132
10.07.04	Class IV Bikeway .....	132
10.07.05	Bikeways at Railroad Crossings .....	132
10.07.06	Bikeways at Roundabouts .....	132
10.07.07	Bikeways at Signalized Intersections.....	132
10.07.08	Bikeways at Un-signalized Intersections.....	133
10.07.09	Bikeway Pavement Markings, Signing, and Striping .....	133
10.08	Pavement Design.....	133
10.08.01	Simplified Pavement Design.....	133
10.08.02	AASHTO Pavement Design .....	135
10.08.03	Pavement Design Report.....	136
10.08.04	Permeable Pavements for Roads, Access Tracts, and Shared Driveways ....	136
10.08.05	Pavement Surface Restoration and Preservation .....	137
10.09	Street Landscaping.....	137
10.09.01	Landscape Strips.....	137
10.09.02	Street Trees .....	138
10.09.03	Ground Cover Planting .....	142



10.09.04	Planting Methods and Maintenance.....	143
10.09.05	Establishment Period .....	143
10.09.06	Irrigation Systems.....	143
10.10	Mailboxes .....	144
10.10.01	Mailbox Locations .....	144
10.10.02	Mailbox Installation.....	144
10.11	Illumination .....	144
10.11.01	General .....	144
10.11.02	Design.....	144
10.11.03	Lighting Design Schedule.....	145
10.11.04	Luminaries .....	145
10.11.05	Light Standards.....	146
10.11.06	Light Standards Foundations.....	146
10.11.07	Service Cabinet, Foundation, Conduit.....	146
10.11.08	Junction Boxes.....	146
10.12	Survey Monuments .....	147
10.13	Guardrail .....	147
10.14	Bollards.....	147
10.15	Bus Transit Facilities .....	147
10.15.01	Bus Stops Locations.....	148
10.15.02	Bus Stops Features .....	148
10.15.03	Bus Pullout Lanes .....	148
10.16	Traffic Control Devices .....	149
10.16.01	Median Islands .....	149
10.16.02	Mountable Curbs.....	150
10.16.03	“Pork Chop” Islands.....	150
10.16.04	Signage .....	150
10.16.05	Crosswalks .....	150
10.16.06	Left and Right Turn Lane Channelization .....	152
10.16.07	Lane Division.....	152
10.16.08	Painted Islands .....	152
10.16.09	Two-way Left-turn Lanes.....	152

10.16.10	Other Pavement Markings .....	153
10.16.11	Construction Area Temporary Traffic Control.....	153
10.16.12	Roadway Barricades .....	153
10.16.13	Traffic Signals .....	153
10.17	Traffic Impact Analysis .....	154
10.17.01	When Traffic Impact Analyses are Required.....	154
10.17.02	Elements of a Traffic Impact Analysis .....	154
10.17.03	Special Uses.....	155
10.17.04	Mitigation Identification .....	155
10.17.05	Recommendations .....	155
10.17.06	Area Circulation Plan.....	156
10.18	Clear Zone – Lateral Separation .....	156
11	City Telecommunication Utility.....	159
11.00	Preface .....	159
11.01	Design Criteria.....	159
11.01.01	Conduits .....	159
11.01.02	Splice Vaults and Pull Boxes .....	159

# 1 General Information

## 1.00 Preface

The City of Auburn has adopted this Engineering Design Standards manual to require the standardization of design elements for consistency and to assure that public safety needs are met. This manual contains engineering standards for use by professional civil engineers when designing facilities within the City of Auburn. The information contained in this manual cannot provide for all situations and conditions that may be encountered. Specific provisions contained within this manual may not be appropriate for all locations and existing conditions. These standards are intended to assist, but not substitute for, competent work by professional civil engineers.

The design requirements contained within this manual do not set legal standards of care, but provide guidance for possible engineering treatment under some circumstances.

Compliance with these standards does not alleviate the design engineer from using sound professional engineering practices and meeting the requirements of the specific utility in question. The design criteria contained herein are the minimum acceptable under standard conditions. Special conditions may require more stringent requirements that will be addressed during the plan review process.

This chapter contains general information on this manual and the City of Auburn.

## 1.01 Definitions

**Note that additional definitions are included in the documents referenced in Section 1.03.**

**AASHTO** - American Association of State Highway and Transportation Officials.

**Access Point** - A driveway or private street that connects to the general public street system. A public street is not considered an access point.

**ACP** - Asphalt Concrete Pavement.

**Activity Centers** - Locations such as schools, parks, retail areas and shopping centers, places of employment, or public service areas that attract people.

**ADT** - Average Daily Traffic. The total two-directional volume of traffic passing through a given point during a given time period, divided by the number of days in that time period.

**Aggregate** - A mixture of various soil components (e.g. sand, gravel, and silt).

**Alley** - Right-of-way, usually narrower than a street with an all-weather surface, which provides access to the rear boundary of 2 or more residential or non-residential properties and is not intended for general traffic circulation. An alley is considered to be a classification of roadway/street.

**Applicant** - The owner or their agent seeking approval from the city for any land use or other related permit or approval referenced in City of Auburn Code and which requires utilization of these Standards. References: See Developer.

**Appurtenance** - Equipment and/or accessories that are a necessary part of an operating utility system or subsystem.

**APWA** - American Public Works Association.

**ASTM** - American Society for Testing and Materials.

**Backfill** - Replacement of excavated material with suitable material compacted as specified.

**Backwater** - Water held back by some obstruction, natural or artificial.

**Backwater Curve** - A plot of depth versus location along the channel containing backwater.

**Bicycle Facilities** - A general term referring to improvements that accommodate or encourage bicycling, including parking facilities, bike racks, bicycle route mapping and bicycle route development.

**Boring/Jacking** - Grade and alignment-controlled mechanical or other method of installing a pipe or casing under a street without disturbing the surrounding medium.

**Breakaway Structure or Breakaway Design** - A structure or installation that has been crash tested in accordance with National Cooperative Highway Research Program procedures. (NCHRP 230).

**Capacity** – (1) The maximum number of vehicles that have a reasonable expectation of passing over a given roadway or section of roadway in one direction during a given time period under prevailing roadway and traffic conditions. (2) The volume of liquid or gas that can be transported by a pipe. (3) The load-carrying limit of a structure.

**Carrier** - Pipe directly enclosing a transmitted fluid or gas.

**Casing** - A larger pipe enclosing a carrier for the purpose of providing structural or other protection to the carrier and/or to allow for carrier replacement without re-excavation, jacking or boring.

**CF** - Cubic Feet.

**Channelization** - The separation or regulation of conflicting traffic movements into definite paths of travel by the use of pavement markings, raised islands or other suitable means to facilitate the safe and orderly movement of both vehicles and pedestrians.

**Check** - A short section of built-up channel placed in a canal or irrigation ditch and provided with gates or flashboards to control flow or raise upstream level for diversion.

**Check Dam** – Short berm used as erosion protection on steep drainage ditches.

**City** - The City Engineer or any designee thereof. References: See City Engineer.

**City Council** - The City legislative authority.

**City Engineer** - The City Engineer for the City of Auburn. References: See Engineer.

**Clean-Out** - A pipe through which plumbing snakes can be pushed to unplug a sewer.

**Clear Zone** - The total streetside border area, starting at the edge of traveled way, available for safe use by errant vehicles. This area may consist of a shoulder, a recoverable slope, a non-recoverable slope, and/or a clear run-out area. The desired width is dependent upon the traffic volumes, speeds, and the streetside geometry.

**CMP** - Corrugated Metal Pipe.

**Coating** - Protective material applied to the exterior of a pipe or conduit to prevent or reduce abrasion and/or corrosion damage.

**CY** - Cubic Yard.

**Dedication** - The transfer of land or the interest of land by the owner of such land to the City for public uses, reserving no other rights than such are compatible with the full exercise and enjoyment of the uses the property has been dedicated.

**Conduit** - An enclosed tubular runway for protecting wires or cables.

**Contractor** - The individual, partnership, firm, corporation or joint venture, contracting with the Developer to do prescribed work.

**Commercial Property Use** - Property with residential developments with four or more dwelling units per parcel or commercial developments. This is consistent with building permit administration in City of Auburn.

**Concrete Plain** - Concrete that is not reinforced with steel.

**Concrete Thrust Blocking** – Concrete that is used to support fittings in water mains.

**Control Zone** - That streetside area defined by the "Control Zone Distance Table"; found in Appendix 5 of the WSDOT Utilities Manual, within the street right-of-way in which placement of utility objects is controlled.

**Corporation Stop** – A brass fitting used to connect service lines to a water main.

**Cover** - Depth to top of pipe, conduit, casing or gallery below the grade of a street or ditch.

**Cross Connection** - Connecting fire, irrigation and drinking water supplies together, or connecting storm and sanitary sewers together.

**Cul-de-sac** - A street closed at one end by widened pavement of sufficient width for vehicles to turn around.

**CSBC** - Crushed Surfacing Base Course.

**CSTC** - Crushed Surfacing Top Course.

**Dead End Street** - Street that accesses the roadway system only at one end. See also Stub End Street.

**Design Speed** - Design speed is the maximum safe speed that can be maintained when conditions are so favorable that the design features of the highway govern.

**Detention Tanks and Vaults** - Detention tanks and vaults are underground facilities for the storage of surface water. Tanks are typically constructed from corrugated metal pipe. Vaults are constructed from reinforced concrete.

**Detention Time** - The average time spent by water in a basin or structure.

**Developer** - The Owner and any agent of the Owner authorized to represent the Owner. References see Applicant.

**Development** - All structures and other modifications of the natural site above and below ground on a particular site.

**DHV** - Design Hour Volume. Hourly traffic volume used for street design and capacity analysis, usually one or more peak hours during a 24-hour period.

**Drain** - Appurtenances to discharge accumulated liquids from casings or other enclosures.

**Driveway Approach** - See Access Point.

**Easement** - A right to use or control the property of another for designated purposes.

**Edge of Traveled Way** - The face of curb for streets that are, or will be constructed to urban standards and the edge of pavement (not shoulder) for streets that are, or will be constructed to rural standards.

**Embankment** - A raised structure constructed of natural soil from an excavation or borrow source.

**Encroachment** - Occupancy of City right-of-way by non-roadway structures or other objects of any kind.

**Engineer** - The City Engineer for City of Auburn or any designee thereof.

**Force Main** - A sewer line that is pressurized.

**Franchise** - Occupancy and use document granted by the City required for occupancy of street rights of way.

**Geometrics** - The arrangement of the visible elements of a street such as alignment, grade, sight distance, widths, and slopes.

**Grade** - Rate or percent of change in slope, either ascending or descending from or along the roadway. It is measured along the centerline of the roadway or access point.

**Gravity Distribution** - A water supply that uses natural flow from an elevated tank or mountain reservoir to supply pressure.

**Hazard** - A side slope, an object, water, or a drainage device that, if impacted, would apply unacceptable impact forces on the vehicle occupants or place the occupants in a hazardous position. It may be either natural or man-made.

**Headwall** - Entrance to a culvert or sluiceway.

**Hydraulic Jump** - The rapid change in the depth of flow from a low stage to a high stage resulting in an abrupt rise of water surface.

**Impervious Layer** - A geologic layer through which no water can pass.

**Infiltration** – (1) The act of stormwater permeating into the ground. (2) Groundwater that enters sewer pipe through cracks and joints, or the movement of water through the upper soil.

**Interception** - Rain that falls on vegetation and other impervious objects, which evaporates without contributing to the runoff.

**Roadway Intersection** - location where two or more roadways intersect, including private roads but excluding alley's, driveways, shared driveways, and access tracts.

**Intersection Sight Distance** - The distance required for a vehicle, traveling at or near the posted speed on a major street, to reduce speed to avoid overtaking a vehicle, which has entered the intersection from the minor street. The entering vehicle can be making right, left-turning movements or crossings.

**Island** - A defined area between traffic lanes for control of vehicle movements and/or for pedestrian refuge.

**Joint Use Driveway Tract** - A jointly owned and maintained tract or easement serving 2 properties.

**Landing** - A road or driveway approach area to any public or private road.

**Lateral** - A sewer line that goes off at right angles to another.

**LF** - Linear Feet.

**Manhole** - An opening in an underground utility system into which workers or others may enter for the purpose of making installations, inspections, repairs, connections, cleaning, and testing.

**Median** - That portion of a divided roadway separating the traveled ways for traffic in opposite directions.

**Mode Split** - The percentage of overall trips made by different means of transportation.

**MPH** - Miles per hour.

**MSE Walls** - Mechanically Stabilized Earth Walls.

**MUTCD** - The Manual on Uniform Traffic Control Devices.

**MVO** – Minimum valve opening.

**NDCBU** - Neighborhood Delivery and Collection Box Unit.

**Neighborhood** – For the purposes of these design standards, a neighborhood is considered to be one or more residential subdivisions and parcels that are interconnected by local residential streets and typically bound by arterial and collector streets or other boundaries such as rivers, critical slopes, or jurisdictional boundaries.

**Outfall** - The pipe that discharges completely treated wastewater or stormwater runoff into a lake, stream or river.

**Passing Sight Distance** - The minimum sight distance required for the driver of one vehicle to pass another vehicle safely and comfortably.

**Pavement** - The combination of gravel base, crushed rock, and asphalt concrete pavement placed on a subgrade to support the traffic load and distribute it to the subgrade.

**Pavement Width** - The distance measured from face of curb to face of curb for curbed sections of roadway or the distance measured from outside edge of shoulder to outside edge of shoulder for shouldered sections of roadway.

**PC** - Point of Curvature.

**PCC** - Portland Cement Concrete.

**Peak-Hour** - That period experiencing the highest volume of traffic.

**Peak Period** - Two hours during any a.m. or p.m. period when vehicle arrival and departure from the site or corridor is the highest.

**Perimeter Streets** – Public streets comprising the perimeter of a particular commercial/industrial development.

**Permit** - A document including any license, permit or franchise authorizing specified use of City right-of-way and granted under the authorization of the regulating agency.

**Pipe** - A structural tubular product designed, tested, and produced for the transmittance of specific liquids and gases under specific conditions.

**PI** - Point of Intersection.

**Plowing** - Direct burial of utility lines by means of a 'plow' type mechanism, which breaks the ground, places the utility line at a predetermined depth, and closes the break in the ground.

**Posted Speed** - Is the signed speed limit along a street.

**Potable** – Drinkable.

**PRC** - Point of reverse curvature.

**Pressure** - Internal gage pressure in a pipe in pounds per square inch, gage (psig).

**Private Street** - A privately owned and maintained access provided for by a tract, easement or other legal means.

**Professional Engineer** - An engineer licensed to practice in the State of Washington.

**Professional Land Surveyor** - A surveyor licensed to practice in the State of Washington.

**Public Street** – A publicly owned facility that provides access, including the roadway and all other improvements.

**PT** - Point of Tangency

**Relocation** - Planned change of location of an existing facility to a more advantageous place without changing the character or general physical nature of the facility.

**Replacement** - Installation of a like element of a utility system or subsystem in the same or near-same physical location normally due to damage, wear or obsolescence of the element.

**Restoration** - All work necessary to replace, repair or otherwise restore the right-of-way and all features contained within to the same or equal condition as before any change or construction thereto.

**Reviewing Agency** - City of Auburn.

**Restricted Access Point** - A driveway or private street that connects to the general public street system, that turning movements are restricted to right in and out only.

**Right-of-way (R/W)** - All property in which the City has any form of ownership or title and which is held for public street purposes, regardless of whether or not any street exists thereon or whether or not it is used, improved, or maintained for public travel.

**Riprap** - Pieces of broken stone used to protect the sides of waterways from erosion.

**Rural** - All lands regardless of current comprehensive plan designation not meeting the definition of Urban.

**Sand Trap** - A section constructed deeper than the rest of the channel to allow sediment to settle out.

**Separate Turn Lane** - An auxiliary lane for traffic in one direction which has been physically separated from the intersection area by a traffic island or stripe. Separate turn lanes may be included within intersections or separated from intersection areas by traffic islands.

**SF** - Square Feet.

**Shoulder** - That portion of the roadway contiguous with the traveled way for accommodating stopped vehicles, for emergency use, and for lateral support of base and surface courses.

**Single Main System** - One main supplies both drinking water and firefighting water.

**Single Occupancy Vehicle (SOV)** - Automobiles transporting the driver only.

**Slab** - A cast concrete member of uniform thickness.

**Standards** – The City of Auburn Engineering Design Standards.

**Stopping Sight Distance** - The distance needed for a vehicle traveling at or near design speed to stop before reaching a stationary object in its path.

**Street or Roadway** - A public way, open for the passage of vehicles and persons. Limits include the outside edge of sidewalks, or curbs and gutters, or side ditches, including the appertaining shoulder and all slopes, ditches, channels, waterways, and other features necessary for proper drainage and protection within the right-of-way.

**Street Frontage** - Any part of private or public property that borders a public street.

**Street Tree** - A tree placed within the public right-of-way.

**Stub End Street** - A dead end street that is planned to be extended and connected to future streets in an adjacent development. Depending on its length, it may or may not require a temporary cul-de-sac.



**Substantial** – In the sole opinion of the City Engineer, of ample or considerable amount, quantity, or size.

**Surface Retention** - That part of a storm that does not immediately appear as infiltration or surface runoff. Retention is made up of depression storage, interception and evaporation.

**Time of Concentration** - The time required for water to flow from the most distant point on a runoff area to the measurement or collection point.

**Traffic Control** - Those activities necessary to safeguard the general public, as well as all workers, during the construction and maintenance of roadway and other facilities within the right-of-way.

**Traveled Way** - That portion of the roadway intended for the movement of vehicles, exclusive of shoulders.

**Trenched** - Installation of a utility in an open excavation.

**Trip** - A one-direction movement that begins at the origin and ends at the destination. For example, a trip movement from a residence to a work place is a trip from home to work.

**Trip Generation** - A general term describing the analysis and application of the relationships that exist between the trip makers, the traffic study area, and the trip making. It relates to the number of trip ends in any part of the traffic study area.

**Uniform Flow** - Flow that has a constant depth, volume, and shape along its course.

**Unopened Right-of-way** - A City right-of-way that exists by dedication or deed, but for which no vehicular roadway has been constructed by the City or other parties, and the street is not maintained by the City.

**Unrestricted Access Point** - A driveway or private street that connects to the general public street system, that has no limitations on turning movements. Left, right turns in and out are permissible.

**Untrenched** - Installation of a utility without breaking the ground or pavement surface such as by jacking or boring.

**Utility** - A company providing such public services as gas, electric power, telephone, water, sewer, or cable television, whether or not such company is privately owned or owned by a governmental entity.

**Vent** - Appurtenance to discharge gaseous contaminants from casings or other enclosures.

**Wetpond** – A stormwater pond that has been designed to retain a permanent pool of water “wetpool” to provide treatment of storm runoff.

**Wetpool** – The permanent pool of water retained in a wetpond or wetvault.

**Wetvault** – A stormwater vault that has been designed to retain a permanent pool of water “wetpool” to provide treatment of storm runoff.

## 1.02 Contact Information

### Permit Center

Physical address:

Auburn Professional Plaza – Customer Service Center (2<sup>nd</sup> Floor)  
One East Main Street

Mailing address:

25 West Main Street  
Auburn, Washington 98001-4998

Email address:

[permitcenter@auburnwa.gov](mailto:permitcenter@auburnwa.gov)

### Public Works Department - Engineering Services:

Phone: (253) 931-3010

### Department of Community Development:

Building Phone: (253) 931-3020

Planning Phone: (253) 931-3090

Email address: [development@auburnwa.gov](mailto:development@auburnwa.gov)

## 1.03 City Reference Material

Unless noted otherwise, reference material referred to herein may be obtained from the City of Auburn's website or by clicking on the hyperlink below:

[Auburn Reference Material](#)

### 1.03.01 City of Auburn Surface Water Management Manual (SWMM)

The City of Auburn Surface Water Management Manual (SWMM) is the 2014 Department of Ecology Stormwater Management Manual for Western Washington (DOE SWMMWW) and City of Auburn Supplemental Manual. The SWMM is a manual of specific requirements related to storm drainage management. See Section 6.01 for more information.

### 1.03.02 City of Auburn Engineering Construction Standards Manual

The Engineering Construction Standards manual sets forth the standards used during the construction of all civil projects within the City's jurisdiction, including the extension of public water, sanitary sewer, storm drainage, and transportation facilities by private developments. The manual is comprised of two parts: Part 1 contains the City's Special Provisions that supplement and modify the current "Washington State Department of Transportation (WSDOT/APWA) Standard Specifications for Road, Bridge and Municipal Construction". Part 2 contains the City's Standard Details, comprised of the City's construction and design detail drawings for temporary erosion control, grading, water, sanitary sewer, storm drainage, and street work within the City that are supplemented by the "Washington State Department of Transportation's (WSDOT) Standard Plans."

Standard Details as referenced herein refer to the current City of Auburn Standard Details included in the City of Auburn Engineering Construction Standards – Part 2, Standard Details. WSDOT Standard Plans as referenced herein refer to current WSDOT Standard Plans. The referenced details and plans shall be the standard except as modified by Part 1 (Special Provisions) of the Engineering Construction Standards and by this document (City of Auburn Engineering Design Standards).

### **1.03.03 Planning Documents**

The following planning documents can be found on the City's website or by clicking on the hyperlinks below:

[Auburn Comprehensive Plan](#)

[Transportation Improvement Program](#)

[Comprehensive Transportation Plan](#)

[2016 Comprehensive Sewer Plan](#)

[2015 Comprehensive Water Plan](#)

[2015 Comprehensive Storm Drainage Plan](#)

### **1.03.04 Informational Handouts**

Handouts are currently available from the City to aid the public in planning and constructing development projects within the City of Auburn. Contact the Permit Center or see the City's website by clicking on the hyperlink below (select 'Information Handouts') for the most current list available:

[https://www.auburnwa.gov/city\\_hall/public\\_works/standards\\_publications](https://www.auburnwa.gov/city_hall/public_works/standards_publications)

### **1.03.05 Additional Technical Information**

Additional design guidance and standards for specialized facilities such as pump stations, pressure reducing stations, traffic signals, and others are not include herein, but may be provided by the City as guidance to supplement efforts during design discussions.

### **1.03.06 Other Reference Material**

The following publications are to be used as additional reference material for design applications not covered by the City's publications and can typically be found on the publishing agency's website:

- A. City of Auburn Code related to development requirements.
- B. Washington State Department of Transportation (WSDOT) "Standard Specifications for Street, Bridge and Municipal Construction" as amended by the City's Special Provisions (Part 1 of the Construction Standards). These will be referred to in City publications as the "WSDOT Standard Specifications."
- C. Washington State Department of Transportation (WSDOT) "Design Manual" (latest edition).
- D. Washington State Department of Transportation (WSDOT) "Standard Plans"
- E. American Association of State Highway and Transportation Officials' (AASHTO) "A Policy on Geometric Design of Highways and Streets" (latest edition).
- F. State of Washington Department of Ecology's "Criteria for Sewage Works Design" (latest edition).
- G. State of Washington Department of Health (DOH) "Water Systems Design Manual" (latest edition).

- H. American Water Works Association (AWWA) Standard Specifications (latest edition).
- I. "IES Lighting Handbook" (Illuminating Engineering Society of North America) (latest edition).
- J. American National Standard for Roadway Lighting ANSI/IESNA RP-8-00 (latest edition).

## **1.04 Deviation from Standards**

In some cases, City standards may not best address a particular engineering application. In these instances, a design deviation from the City's standards may be requested from the City Engineer. Except deviations for City capital improvement projects, deviations shall be made using the City's Deviation Request Application and shall include applicable engineering justification for the deviation. Deviation requests and supporting justification must be sealed by a professional engineer. The City Engineer will evaluate the request and notify the applicant of a decision within 15 working days upon receipt of a complete deviation request or with the completion of the first review of the development review plans or plats (for Short Plats, Plats, FAC's and Grading Permits), whichever is later. Additional City review time may be required in certain circumstances and will be coordinated with the applicant. For deviation applications that are associated with a preliminary plat application submitted in compliance with Chapter 17.10 ACC, the deviation application and a recommendation from the City Engineer must accompany the preliminary plat to the hearing examiner. The hearing examiner must obtain the concurrence of the City Engineer for any requests to modify any City of Auburn design or construction standard. Approved deviations must be shown on the final civil site improvement plans as specified in Chapter 3.

Deviations for City capital improvement projects will be reviewed and approved by the City Engineer during design review. The City Engineer signing the final plans as approved for construction constitute approval of any deviations from these Standards.

The deviations identified in the following subsections may be obtained from the City of Auburn:

### **1.04.01 General Deviations**

General deviations apply to all engineering design standards except for the Surface Water Management Manual's Minimum Requirement deviations.

The engineering design deviation, with compelling supporting justification, shall clearly demonstrate the engineering design standard for which the deviation is being sought is not physically or technically possible, would have undesirable impacts to public or private infrastructure and property, or would impact critical areas.

Additionally, the proposed deviation will meet or exceed the corresponding City standard for the following applicable criteria:

- A. The functional intent of the design element.
- B. Safety factors associated with the design element.
- C. Operational concerns associated with the design element.
- D. Maintenance concerns associated with the design element.
- E. Liability concerns associated with the design element.

- F. The capacity and/or efficiency of the design element.
- G. The design life, historical performance, and durability of the design element.
- H. The aesthetic and visual impacts of the design element.
- I. The cost effectiveness and availability of any replacement components or materials.
- J. Consistency with the spirit and purpose of the corresponding City design standard.
- K. Demonstration that the environment will not be adversely affected.
- L. Supported by published industry standards.
- M. The effect on buildable lands within the City of Auburn.

#### **1.04.02 Surface Water Management Manual (SWMM) Deviations**

A deviation request from any of the 10 minimum requirements in the SWMM goes through a different process which includes a public notice requirement. This is to insure that the Department of Ecology mandated surface water regulations are complied with. The 10 Minimum Requirements of the SWMM can be found in Section 6.01.

Requests for deviations from the 10 Minimum Requirements of the SWMM shall be in accordance with ACC 13.48.226 and these standards.

#### **1.05 Appeal of City Engineer's Decision**

Appeal of the City Engineer's decision shall follow the following procedure:

The applicant shall have 15 working days from the date of receipt of the City Engineer's decision in which to submit a written notice to the Public Works Director contesting the decision of the City Engineer. The Public Works Director shall then have 15 working days to notify the applicant of a decision to uphold or modify the City Engineer's decision. For appeals of engineering deviations requests, the Public Works Director's determination shall be final.

#### **1.06 Changes to Standards**

Per ACC 12.04.010, the City Engineer is authorized to make any additions, deletions, or modifications stated in these Standards with consultation with the City Council on policy issues or broad Citywide implications.

## **1.07 Downtown Sidewalk Design Guidelines**

In 2007, the City Council passed Resolution 4271 that approved and adopted for inclusion into the Engineering Design Standards the Auburn Sidewalk Design Guidelines (Guidelines). Since then, the Guidelines have been revised in consultation with the Downtown Redevelopment Committee (formerly a committee of City Council members) and at the Council Study Session on November 23, 2020. The Guidelines provide general design concepts for sidewalks, street lights, street corners, street trees, and crosswalks in the Downtown Urban Center (DUC) Zone.



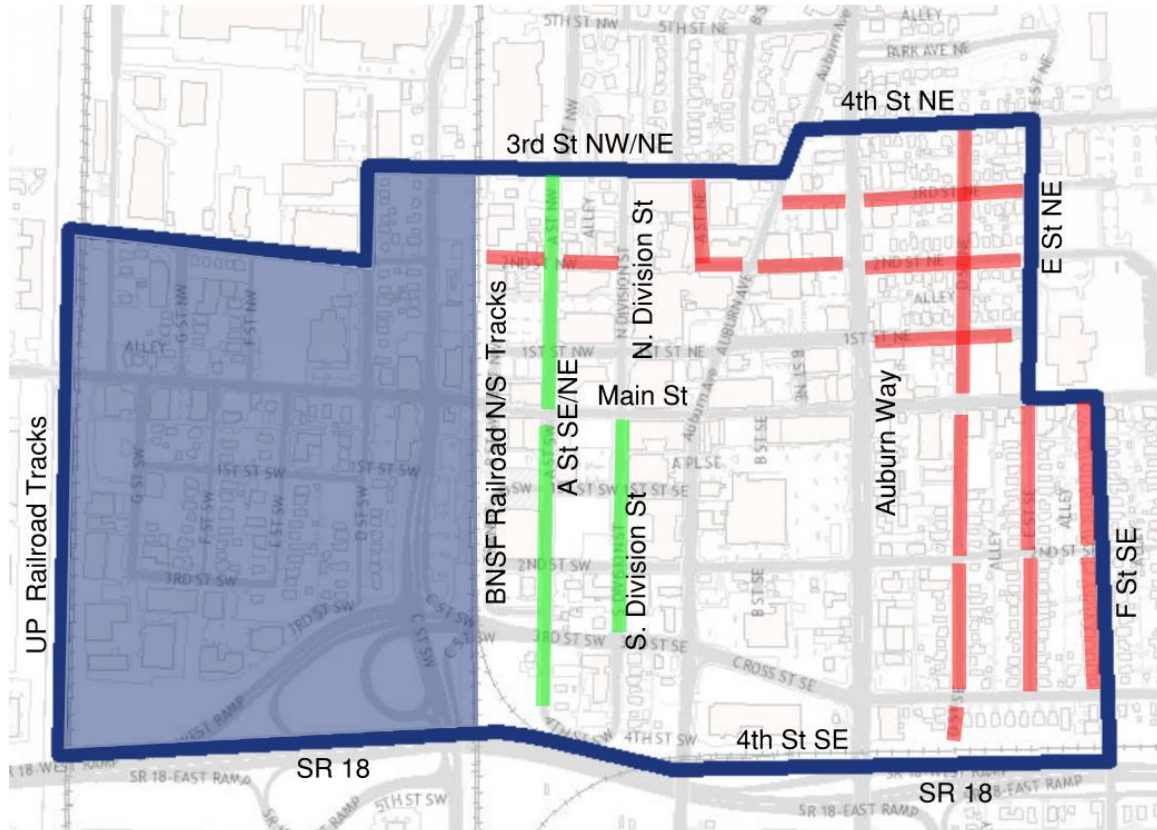

### **1.07.01 Applicability**

1. The Guidelines are applicable within the boundaries of the Downtown Urban Center (DUC) zone as defined in the Comprehensive Plan zoning map, except as specified herein.
2. Where the DUC zone boundaries are shown along or within a street, the Guidelines apply to both sides of the street.
3. Streets west of the north/south Burlington Northern Santa Fe (BNSF) railroad tracks are exempt from the Guidelines.
4. All local streets, except N. Division Street and B Street NW, are exempt from the Guidelines.
5. The Guidelines apply to A Street NE/NW except that sidewalks may be 8 feet wide and street tree grates may be 4 feet wide x 6 feet long on the corridor.
6. South Division Street from 3rd Street SE/SW through W Main St, also referred to as the "Promenade" shall have a distinctive design separate from these Downtown Auburn Design guidelines. Unless specifically noted herein or unless otherwise directed by the City Engineer, these guidelines will not apply to this area. However, they are intended to be compatible with that design. Wherever infrastructure is replaced, restored, or expanded within the Promenade area, the infrastructure shall be built to match those project specific standards.

Figure 1-01 Downtown Sidewalk Design Guidelines Applicability Map



**LEGEND**

-  Approximate DUC Zone Boundary (See current Comprehensive Plan)
-  Local Streets Exempt from Guidelines
-  Streets with Exceptions or Additional Design Guidance
-  Exempt area west of BNSF Railway tracks

**1.07.02 Downtown Sidewalks**

Sidewalks shall be per **City of Auburn Standard Detail T-15** and will also include a 2-foot x 2-foot square scoring pattern with a light broom finish with minimal scoring depth to allow for easy cleaning. Sidewalks shall be a minimum of 10 feet in width.

Sidewalks shall maintain a minimum walking zone of 5 feet in width, free of all obstructions including utilities, signage, street trees, furniture or other elements, permanent or temporary.

A single row of bricks shall be used at transition points such as driveways and connections between new and old sidewalks per in **City of Auburn Standard Detail T-44**.

**Figure 10-2 Downtown Sidewalk Brick Transition Illustration**

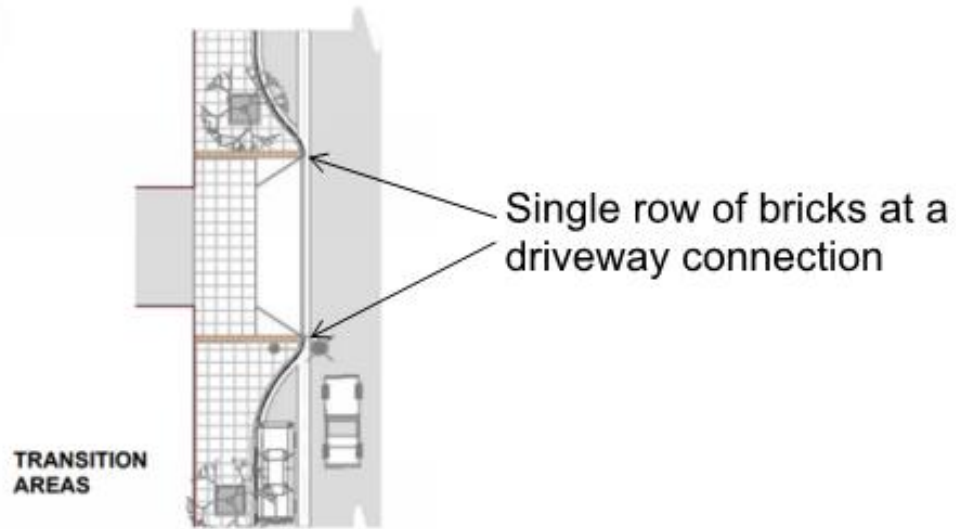

### **1.07.03 Street Corners**

Corner bulbs shall be integrated into corners where on-street parking is allowed, dependent upon the adjacent street geometry, presence of bus routes or other large vehicle use, as determined by the City Engineer.

All street corners where a corner bulb is required or where at least 1 leg of the street corner has sidewalk that are at least 10-feet wide shall be constructed of brick pavers in a rectangular pattern as shown in the figure below. The specific type of brick pavers shall be approved by the City, including shape, size, and color.

Patterns shall extend from the back of curb to the building face and a minimum of 10 feet in either direction from the corner of the property lines.



**Figure 10-3 Downtown Street Corner Illustration**

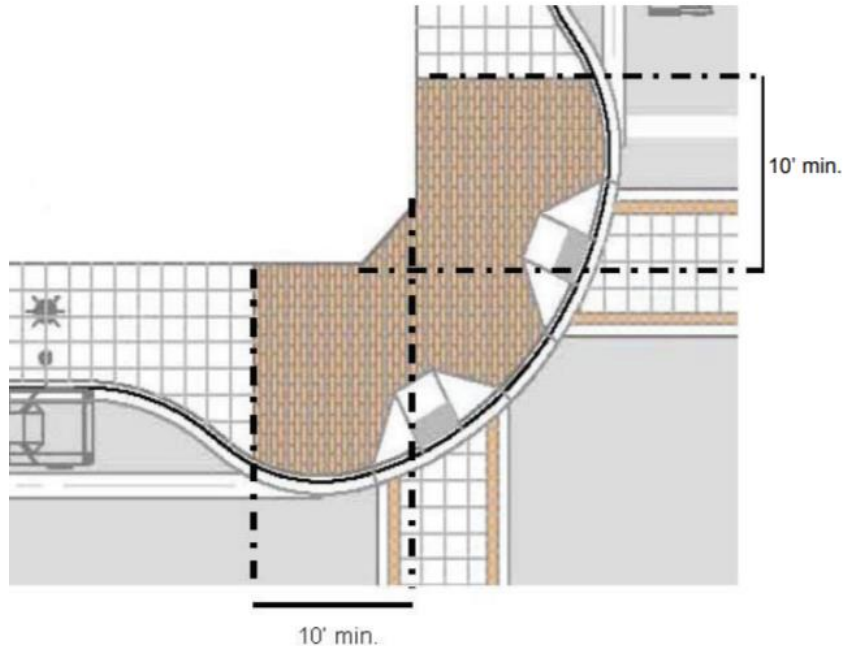

An existing street corner that does not meet the requirements of the Guidelines shall be re-built in its entirety to meet the requirements of the Guidelines with the construction of a partial or full replacement of 1 or more curb ramps at the street corner.

#### **1.07.04 Street Trees in Grates**

Sidewalks that are 10-feet wide or wider require street trees with root barrier per **City of Auburn Standard Detail T-06** in grates per **City of Auburn Standard Detail T-30**. An exception to this requirement is that street trees and grates are not generally required on Auburn Way North/South but may be considered on a case-by-case basis with approval by the City Engineer.

Street trees are generally required to be installed at 40 feet to 50 feet on center and be located 2-1/2 feet from the back of curb. Street and pedestrian lighting should be placed in between the street trees. Trees may be placed at either greater or lesser intervals to maintain sightlines for safety or for other reasons, subject to approval of the City Engineer.

Additional street tree requirements, including species selection, is included in Chapter 10 of these standards.

#### **1.07.05 Pedestrian Crosswalks**

Marked crosswalks shall be per **City of Auburn Standard Detail T-43**.

An existing marked crosswalk that does not meet the requirements of the Guidelines shall be re-built in its entirety to meet the requirements of the Guidelines with the any of the following construction activities:

- On an arterial street, full depth pavement re-construction across half or more of the crosswalk width.
- On a non-arterial street, surface pavement restoration across half or more of the crosswalk width.

The crosswalk width is measured from face of curb or pavement edge at the pedestrian pathway entry into the vehicle travel way to curb face or pavement edge at the pedestrian pathway departure from the vehicle travel way. This distance is measured through medians, islands, and other pedestrian refuge areas.

#### **1.07.06 Lighting and Traffic Signals**

Pedestrian and street lighting shall be per **City of Auburn Standard Details T-28 and T-39**. Traffic signals shall be per **City of Auburn Standard Detail T-38**.

## **2 Plan Approval Process**

### **2.00 Preface**

This chapter contains standards and procedures that apply to the review and approval process for civil engineering plans. Development or redevelopment of property within the City of Auburn, and/or within the limits of Auburn's Utility Service Area, that require civil engineered plans to support a development action must follow the processes outlined in the subsections below.

### **2.01 Types of Plans**

This section contains information regarding the types of civil engineering plans submitted to the City. Specific plan requirements are described in detail in Chapter 3.

Civil engineering plans submitted to the City for review fall within the following four categories.

#### **2.01.01 Grading Plans**

Grading plans are required prior to the issuance of a Grading Permit and before commencement of construction if triggered per Auburn City Code 15.74.

#### **2.01.02 Building Site Plans**

A Building Site Plan includes all civil site development requirements including site layout, building location, site access, parking, code required landscaping, utility service, and storm drainage control. An approved Site Plan is required prior to the issuance of a Building Permit and before commencement of construction.

A building Site Plan is required for all new non-residential developments and residential construction of 3 units or more per lot.

#### **2.01.03 Public Facility Extension (FAC) Plans**

An approved Public Facilities Extension Plan (FAC Plan) is required prior to installing new or improving existing public sanitary sewer, water, storm drainage, and/or transportation facilities.

#### **2.01.04 Other Plans**

Some projects may also require other types of plans. The requirements for these additional plans will usually be addressed early in the submittal process. These plans could include, but are not limited to, the following:

- A. Landscape plans.
- B. Land clearing plans.
- C. Irrigation plans.
- D. Wetland plans.
- E. City Owned Retaining Wall Plans and Structural Calculations
- F. Illumination/Site Lighting Plans

## 2.02 Review and Approval Process

### 2.02.01 Submittals

When submitting civil engineering plans to the City for review, the following steps are required to insure a complete submittal and timely approval of civil engineering plans:

- A. Applicants are encouraged to meet with City staff prior to plan submittal. (Pre-application information is available through the City of Auburn Permit Center) All plans and associated documents submitted to the City will be assigned a project number and receive a preliminary review to make sure they adequately address the minimum requirements of a complete application. Any such plans and associated documents not meeting these requirements will be returned to the applicant or the applicant's designee as unacceptable for review, with a written explanation of necessary corrections required prior to the subsequent resubmission.
- B. Prior to preparing civil engineering plans for submittal, the applicant shall obtain a [Civil Site Improvement Submittal Packet.pdf](#) from the City, for the appropriate type of plans. This packet contains information necessary to prepare plans in conformance with City guidelines along with the minimum required civil site improvement application. The checklists within the Civil Site Improvement Submittal Packet shall be completed and submitted along with the civil engineering plans.
- C. Civil Engineering plans and associated documents are to be submitted to the City for processing. All submittal documents (Reports & Plans) must be single .pdfs and not require collating, with file names that clearly state the document type and may be submitted through an electronic transfer file system setup by the City Permit Center. If you have any questions regarding the required items or would like to setup a submittal appointment, please contact the City Permit Center at [applications@auburnwa.gov](mailto:applications@auburnwa.gov), 253-931-3020 or Development Engineering at [development@auburnwa.gov](mailto:development@auburnwa.gov), (253) 876-1969, or in person at the City of Auburn Permit Center on the Second Floor of the Auburn Professional Plaza, One East Main Street.
- D. After the receipt of a completed Civil Site Improvement Application and application fees, the City will make a preliminary review of the plans and supporting data to verify the scope of the proposed extension(s) and check for completeness of the application. The City requires 28 calendar days from the date of initial submittal to determine if the application is complete. Once the City is satisfied with the completeness of the application and the application fees have been paid, the 1<sup>st</sup> detailed civil site improvement review will begin.
- E. Once the length of the public extension(s) and/or hours required for review/inspection have been verified/calculated, 30% of the review and inspection fees are due with the application for 2<sup>nd</sup> review. Detailed FAC Plan review work for the 2<sup>nd</sup> review will not continue until 30% of the review and inspection fee is paid. If no 2<sup>nd</sup> review is needed then payment of the full review and inspection fee is due before the City signs the facility extension agreement.
- F. All proposed public right-of-way dedications shall be dedicated to the City prior to start of construction with the exception of plats and short plats. A title report pulled within 30 calendar days of the application will be required to confirm property ownership and to verify that the portions of the property dedicated as right-of-way and/or easements have been cleared of encumbrances. The applicant is responsible for clearing all encumbrances the City determines to be inconsistent or

in conflict with the intended purpose of the dedications. Title insurance shall be provided to the City for right-of-way dedications in the amount of \$50.00 per square foot of right-of-way area dedicated, or other amount as proposed by the Developer and accepted by the City Engineer. Easements shall be executed by the Applicant prior to start of construction. Easement documents will be held by the City until the end of construction, at which time the easement exhibits and descriptions may need to be updated by the Applicant, based on as-built conditions, except easements that are being granted by someone other than the Applicant which will be recorded prior to the start of construction. Once the easements are confirmed to match field conditions, the easements will be recorded by the City.

- G. The following applicable information may be required along with the plan submittal:
  - 1. Title report (required if right-of-way is being dedicated).
  - 2. The final biologist report, including the wetland mitigation plan, when appropriate.
  - 3. Traffic reports.
  - 4. A copy of other applicable applications (Short Subdivisions, Subdivisions, etc.).
  - 5. Letter indicating how SEPA and/or other applicable application conditions have been accounted for in the development/plan process.
- H. All final plans, calculations, or reports submitted for review shall be stamped by a Professional Engineer. Electronically signed seals will only be accepted if they meet the requirements of WAC 196-23-070.
- I. Where the plan review process is running concurrent with other applications (SEPA, Subdivisions, etc.), the above-referenced information may not be available at time of plan submittal. In such instances, other required applications shall be provided prior to final plan approval.
- J. All final approved Plan submittals shall include the associated electronic AutoCAD files.
- K. If the project is to be phased, phasing plans must be submitted per the requirements specified herein.

### **2.02.02 City Review**

The City will review plans and associated calculations, reports, and AutoCAD files for conformance with City development requirements, standards, and policies. Marked up construction drawings, calculations, reports, and written plan review comments will be returned to the applicant's designated contact person for revisions. The applicant's engineer shall revise construction drawings, calculations, or reports to address City plan review comments and provide comprehensive comment responses with the updated documents. The revised drawings (the required number will be determined by the City) and associated calculations and reports, along with the redline comments, shall be resubmitted to the City for additional review.

### **2.02.03 Plan Approval**

Once the plan review process is completed and all City review comments have been addressed, the City will request that one electronic copy of the sealed plans and reports be submitted for approval.

- A. Final reproducible plans shall be produced in .pdf format, signed and stamped by a professional engineer and provided to the City for approval signatures, along with the final AutoCAD files. Electronically signed seals must meet the requirements of WAC 196-23-070 and also provide permissions for City staff to apply signatures to the approved plans. The City will return the signed and approved plans to the Applicant.
- B. All applicable AutoCAD files shall be submitted to the City on a compact disk, flash drive or electronically transferred to [development@auburnwa.gov](mailto:development@auburnwa.gov) for integration into the City's Geographic Information System (GIS). For more information on AutoCAD file submittal, please see Appendix F of this chapter.
- C. If after plan approval, but prior to construction, the applicant desires to make changes to the approved plan(s) a revised plan(s) reflecting such changes shall be required. In such cases, the revised plan(s) shall be submitted to the City for review, comment, and approval by the City. Inquiries regarding plan updates during construction should be made to the Development Review Engineer assigned to the project or to [development@auburnwa.gov](mailto:development@auburnwa.gov).

#### **2.02.04 Project Close Out**

The following is the general process required for accepting construction completion on a project:

- A. Construction Record Drawings (also referred to as the Construction Redlines) refer to the field changes the Applicant clearly tracks and marks on the final approved and signed plans that are retained throughout construction, in accordance with the requirements specified in the Construction Standards.
- B. After completion of construction, the Applicant shall submit the Construction Record Drawings to the City electronically for review and comment. After the City has concurred the Construction Record Drawings reflect the as-built conditions and meet City record drawing standards, as described in the City Construction Standards, the Applicant shall utilize them to produce the Final As-built Record Drawing set for submission to the City. A copy of the "Record Construction Document Packet" which outlines the complete record drawing process in detail can be obtained from the City.
- C. The Applicant shall also provide the City the current AutoCAD drawing files to reflect any revisions that occurred after plan approval and submit an electronic PDF set to the City.
- D. The City will apply an 'As-Built' stamp on each sheet of the submitted Final As-built Record Drawing set and apply a "Record Drawing Certification" block on the Cover sheet. The Record Drawing Certification will be signed by the City and the Final As-built Record Drawings will be archived and imported into the City's GIS database..
- E. A final Stormwater Site Plan certification letter shall be stamped, signed and submitted by the Engineer of Record to the City verifying that the storm facilities were installed as designed or note any minor changes during construction that require no changes to the Stormwater Site Plan report.
- F. Submit an electronic copy of the Stormwater Site Plan report and Geotechnical Report if there have been changes during construction.

The following shall also be completed for projects prior to project close out.

- A. All legal documents, including but not limited to a Bill of Sale and Utility Easements, shall be updated as needed and executed.
- B. For all FACs, a "Developer Contributions Document" for all public transportation, water, sewer, and storm facilities constructed as part of the project shall be obtained from the City, completed, and returned electronically to the City.
- C. All Maintenance Bonds or Assignments of Funds for the 1 to 2-year maintenance period shall be in place.

# 3 Plan Preparation Requirements

## 3.00 Preface

This chapter describes City requirements for plans submitted to the City for review and approval. Civil engineering plans must meet these standards in order to move through the review process in an efficient manner and in order to receive approval.

## 3.01 General Requirements

The following general requirements apply to civil engineering plans submitted for review and approval by the City:

- A. The general construction requirements for the City shall be those contained in the City of Auburn's current Engineering Construction Standards Manual which supplements or modifies the "Washington State Department of Transportation (WSDOT) Standard Specifications for Road, Bridge and Municipal Construction," except where supplemented or modified by the City in this manual.
- B. The civil engineering plans shall reference City Standard Specifications, Standard Details, and WSDOT Standard Plans as necessary. The City's Standard Specifications and Standard Details are contained in the Engineering Construction Standards, a copy of which shall be on-site during construction.
- C. All civil engineering plans and reports shall be prepared and sealed by a professional engineer.
- D. Property surveys shall be performed and prepared per WAC 332-130-145, sealed and signed by a professional land surveyor and be tied to the current City datum (NAVD 88) and horizontal control datum shall be NAD83 (1991) as officially adjusted and published by the National Geodetic Survey. (WAC 332-160-060 and RCW 58.20). A list of City Benchmarks is available upon request.
- E. All civil engineering plans and calculations shall be neat, uncluttered, legible, and in conformance with the requirements herein.
- F. All plans shall be prepared utilizing AutoCAD software in accordance with the standards specified herein.
- G. For a Development project, all deviations from City's Engineering Design and Construction Standards must be shown on the plans with a note call-out and description that references the City assigned deviation number and deviation approval date. The format of these call-outs and note descriptions shall be as shown in Appendix C of this Chapter.
- H. Except as approved otherwise by the City Engineer, a project may qualify for a Minor Grading Permit Submittal. Refer to Appendix E for project thresholds to qualify for a Minor Grading Permit and the submittal requirements.

## 3.02 Plan Format

The City requires that plan sets be submitted in an order consistent with this section. Depending on the complexity or simplicity of the project, the amount of detail and content required will be subject to change. Depending on the scope of the project the civil site improvement plans may



be comprised of a combination of the grading, site and facility extension (FAC) plan elements outlined below to create a set of Civil Site Improvement Plans.

Civil Site Improvement Plans shall consist of the following sheets:

- A. Cover sheet (See 3.04.01).
- B. Temporary Erosion and Sediment Control (TESC)/Demo Sheet (Land Clearing when applicable) (See 3.04.02).
- C. Grading and Private Storm Drainage Plan (See 3.04.03).
- D. Utility Plan and Profiles if applicable (See 3.04.07 & 3.04.09).
- E. Street and/or Storm Plan and Profiles if applicable (See 3.04.08 & 3.04.09).
- F. Street Cross-Sections and Additional Street Elements if applicable (See 3.04.09).
- G. Cross-Sections (See 3.04.04).
- H. Details (See 3.04.05).
- I. Street and/or Site and Landscape Plan (See 3.04.10).
- J. Irrigation Plan if applicable (See 3.04.11).

If a separate associated grading plan has been submitted and approved, those areas covered under the grading plans will not need to be readdressed in the building site plans.

### **3.03 General Plan Requirements**

#### **3.03.01 Standard Plan Format**

Applicable information in this section shall be shown on the plan set.

- A. Each sheet of the plan set shall be stamped by a professional engineer.
- B. North arrow.
- A. The title block shall include the development/Capital project title (in bold print), the name, address and phone number of the firm preparing the plan and the owner/developer, a revision block (showing the date of the latest revision), page of pages numbering, and sheet title (e.g., road and storm drainage, grading, erosion/sedimentation control, water and sanitary sewer).
- B. Indicate units of measurement for all slope callouts as either percent (%) or feet per foot (ft./ft.). Do not mix units of measurement on a plan set.
- C. Provide all match lines with matched sheet numbers (stationing).
- D. The street classification shall be provided under the street name on all plan views.
- E. For the approved Development project plans, a City of Auburn approval block (4"x2") on each plan sheet shall be provided in lower right corner of each plan sheet. Show project reference numbers (BLD for Building Permit, FAC for Public Facility Extension Plan, STM for Storm Permit and/or GRA for Grading/Erosion Control Permit) in the approval block area. A blank Auburn Engineering approval block is shown as block B-3 in Appendix A of this chapter.

The locations of the title blocks, approval blocks, and engineering stamp shall remain consistent throughout all the plan sheets.

#### **3.03.02 Drafting Standards**

Drafting requirements are as follows:

- A. Plan sheets shall be formatted to print on 22"x34" size paper. Any variation must be approved by the City prior to plan submittal. Approved plans shall be produced per Section 2.02.03 of the Engineering Design Standards. Margins shall be set to provide for ½ size drawings to fit on 11"x 17" sheet size.
- B. Lettering size shall be no smaller than one tenth (1/10) of an inch in height and shall be uppercase. Callouts and other information shall be printed horizontally in most cases.
- C. Existing features shall be shown with dashed lines and/or screened back APWA line types and symbols (screening 45%).
- D. Proposed features shall be shown with APWA symbols and line types. The intent is to clearly distinguish existing features from proposed improvements.

E. Minimum scale shall be:

1. Site work: 1" = 40' horizontal.
2. Public facility work: 1" = 20' horizontal.

Vertical scales are to be 1/10<sup>th</sup> the horizontal scale except for public facility work in areas with steep slopes, 1" = 5' may be used in place of 1" = 2'.

Use a scale that best utilizes paper space and gives the best overall view of the site.

F. Use APWA AutoCAD symbols and line types in the legend to identify both existing and proposed improvements and utilities.

G. Electronic AutoCAD files shall be prepared in accordance with the Layers Standard included in Appendix F of this chapter. A .dwt file containing the AutoCAD layers can be found on the City's website or by clicking on the following hyperlink: [Development AutoCAD Layers and Linetypes](#)

H. Electronic AutoCAD files shall be geo-rectified per the standards specified herein.

### **3.04 Plan Sheet Elements**

The following section covers the basic elements that are required to be shown on the different plan sheets. While all plan sets will have a cover sheet, there are other sheets covered here that may or may not be included in a particular projects plan set.

#### **3.04.01 Cover Sheet**

The Cover Sheet and General Information Sheet(s) shall incorporate all the requirements listed in Section 3.02, plus the following applicable items:

- A. A general scaled site plan covering an area approximately 10 inches square.
- B. Vicinity map (approximate scale) with north arrow covering an area approximately 5 inches square.
- C. Site address.
- D. Owner/Applicant, address, contact, phone number, and e-mail address.
- E. Engineer/Surveyor/Architect address, contact, phone number, and e-mail address.
- F. Elevations with City datum (NAVD 88) tied to City benchmarks with reference to the benchmarks' numbers and locations indicated. Horizontal control information (NAD83). See Appendix E of this chapter for more information on survey requirements.
- G. Monuments used for horizontal control per the City's horizontal control datum NAD83 (1991) with a description of the monument and northing and easting.
- H. The permit number in 1 inch bold lettering shall be above the title block (located on the right side of the sheet) on the cover sheet only.
- I. Sheet Index with reference to all civil plan sheets.
- J. Legend of all existing and proposed lines and symbols used on the plans.
- K. Full legal description(s) including quarter section, section, township, and range.
- L. Parcel number(s).
- M. Site zoning and adjacent zoning (may be shown on a separate vicinity map sheet).

- N. Applicable plat name and lot numbers.
- O. Applicable site information including the number of parking spaces required and the number of parking spaces provided.
- P. Type of building construction as defined by the adopted Building Code and the building height as defined in Appendix D of the International Fire Code.
- Q. Site access including adjacent driveways, roadways, and intersections that may have an impact on the location and type of site access.
- R. An overall site plan key map shall be shown if the plan set includes more than 4 plan sheets, unless otherwise directed by the city.
- S. Construction Sequence outlining a basic construction schedule for all elements of the project. (See Section 5.05 for a sample construction sequence related to storm and TESC elements) In addition, depending upon the nature of the project, the construction of some public facilities may also dictate separate construction sequencing requirements that will also need to be indicated on the plans.
- T. The City of Auburn General Notes as shown in Appendix B of this chapter.
- U. Provide a list of the additional non-building permits required for this project. The City will update this list with the 1<sup>st</sup> review comments.
- V. Indicate approximate fill and excavation quantities in cubic yards. Refer to the Civil Site Improvement Submittal Packet (FAC & GRA) checklist located on the City's website for required format.
- W. Storm drainage related quantities and information required to support calculation of System Development Charges (SDC). Refer to the Civil Site Improvement Submittal Packet (FAC & GRA) checklist located on the City's website for required format.
- X. The City of Auburn Engineering Approval Block as shown in Appendix A of this chapter.

### **3.04.02 Temporary Erosion and Sediment Control (TESC) Plan Sheet**

TESC design shall be in accordance with Chapter 5 – TESC, Clearing, and Grading, and include the following applicable items:

- A. Marked clearing work limits, environmentally sensitive areas and their buffers, and trees that are to remain.
- B. Indicate the location of the construction entrance
- C. Provide the onsite stormwater facilities during construction.
- D. Indicate the minimum temporary erosion control measures to be used on the site during construction, this may include, silt fencing, interceptor ditches, detention or retention facilities, flow control structures, etc.
- E. Show containment locations for storing pollutants, including waste materials and demolition debris, prior to their removal from site.
- F. In the construction sequence, provide a phasing schedule for installing and removing TESC BMPs, including the transition from the temporary storm drainage system to the permanent storm drainage system.

- G. All existing site features and conditions shall be shown on this sheet including the existing topography.
- H. This sheet may also function as a demolition site plan and indicate all existing features and structures to be removed/demolished and those that will remain.
- I. Provide the Auburn Grading and Erosion Control Notes as shown in Appendix B of this chapter.

### **3.04.03 Grading and Private Storm Drainage Plan Sheet**

The Grading design shall be in accordance with Chapter 5 – TESC, Clearing, and Grading, and include the following applicable items:

- A. Indicate slope of any fill or cut slopes.
- B. Show or provide reference for type of fill material and associated compaction requirements.
- C. Show existing significant trees (6 inches in diameter and larger for evergreens and 4 inches in diameter or larger for deciduous). Indicate if tree is to either be retained or removed.
- D. Provide temporary storm drainage retention or detention facilities including City control structure, water surface (W.S.) elevations, seasonal high groundwater elevation, orifice sizes, design storms for the W.S. elevations, and release rates.
- E. Show horizontal setback between the bottom of any fill placement and the top of the bank of a defined drainage channel per requirements noted in section 5.03.03.
- F. Show typical ditch sections.
- G. Show connections of building roof and foundation drains to the site drainage system.
- H. Show the existing topography shaded back and overlaid by the proposed grades.
- I. Show existing and finished elevations and contours. Spot elevations may be required for relatively flat sites to supplement the contour elevations as necessary to adequately reflect existing and finish grades. Provide spot elevations along property line and a minimum of 30 feet beyond property line (at least 50 foot intervals).
- J. Reference standard City of Auburn Detail Numbers appropriately. If a project specifies modification to a Standard Detail, a new detail must be shown on the plans.
- K. Provide notes to protect and maintain erosion control facilities during grading operations.
- L. Provide arrows to indicate drainage flow direction on paved surfaces.
- M. Show layout of the entire storm drainage pipe with length, slope, and material type labeled and direction of flow indicated.
- N. Provide site specific details and cross-section sheets for storm drainage detention or retention facilities.
- O. Indicate the emergency overflow to the public storm system.
- P. Show berm dimensions, materials, compaction requirements for ditches and detention ponds where applicable.

- Q. Show locations of manholes and catch basins, indicating type, stationing, offset, lid type, rim and invert elevations. Number manholes and catch basins consecutively.
- R. Show existing and proposed sanitary sewers and water mains, identifying crossing and minimum vertical distance between utilities.
- S. Provide type of material and size of energy dissipaters (riprap, etc.).
- T. Provide details and cross sections of all low impact development, water quality, and flow control facilities for stormwater runoff.
- U. Show trash racks, if applicable.
- V. Show locations, widths and types of easements.
- W. Show locations and types of pumps, if applicable.
- X. Provide planting and seeding requirements with establishment procedure in construction sequence for water quantity and quality systems.
- Y. Show finish floor elevations.
- Z. Show the controlling downstream storm drainage elevations including the associated design conditions.
- AA. For ponds, provide: aesthetics, fencing, power (if applicable), maintenance access, control structure, critical water surface elevations, and other items, such as walls and liners.
- BB. Address bypass surface flows.
- CC. Address subsurface flows and indicate water surface elevations.
- DD. Some projects may be able to combine the grading sheet with the erosion control and demo plan depending on the complexity of the project.

#### **3.04.04 Cross-Section Sheet**

The Cross-Section plan sheet(s) shall be provided for projects that propose grading activities 10 feet or closer to the property line, excavations over 5 feet or fill over 8 inches in depth or more and have the following applicable items:

- A. Cross-sections for fill and grading shall be shown through all properties to at least 30 feet beyond the property lines. Adequate cross-sections shall be shown to represent the site. At a minimum this shall include one shown in the north direction (west-east from left to right) and one shown in the east direction (south-north from left to right) cross-section.
- B. This sheet may also contain cross-sections for the temporary storm drainage pond.
- C. The scale used for the site cross-sections on this sheet should match the scale on the other sheets.

Some projects may be able to combine the cross-section sheet with the grading sheet depending on the complexity of the project.

#### **3.04.05 Detail Sheet**

The Detail sheet(s) shall have the following applicable items:

- A. Any detail that is specific to this project.

- B. City of Auburn Standard Details are not to be shown on this sheet unless they need to be modified for a project specific application, in which case the detail would be shown with the modifications explicitly called out/labeled and shall not include the City Engineer's signature from the original detail.
- C. Storm control manholes shall be shown on this sheet.
- D. This sheet shall contain cross-sections for the storm facility.

City of Auburn Standard Details and WSDOT Standard Plans are to be called out on the applicable plan sheet using the detail or standard plan number.

### **3.04.06 Public Storm Drainage Plan Sheet**

Grading and Storm Drainage system design shall be in accordance with Chapter 5 – TESC, Clearing, and Grading, and Chapter 6 – Storm Drainage Facilities (which incorporates by reference the SWMM), and include the following applicable items:

- A. The layout of all the storm drainage pipes with the length, slope, and material type indicated in the labeling of the storm drainage pipes. Provide arrows to indicate the direction of flow into the structures.
- B. Typical ditch section.
- C. Location of manholes and catch basins. Indicate type, stationing, offset, rim and invert elevations, and number manholes and catch basins consecutively.
- D. Existing and proposed sanitary sewers and water mains. Identify crossings and minimum distance between utilities.
- E. Building downspouts or footing drain locations, inverts and connections to the storm drain system.
- F. For single-family home sites, indicate means for collection and discharge of water from roof, foundation drains, and driveways.
- G. Provide arrows to indicate drainage direction in parking lots, roadway intersections and cul-de-sacs.
- H. Reference to the detail/BMP and/or cross-section sheets for storm drainage detention or retention facilities such as the control discharge structure and pond cross-sections. Indicate water surface elevations, allowable discharge rates, and design storms.
- I. Show an emergency overflow to the public storm drainage system.
- J. Berm dimensions, material, and compaction requirements for ditches and detention ponds where applicable.
- K. Indicate type of material and size of energy dissipaters (riprap, etc.).
- L. Provide details of the storm drainage water quality facility.
- M. Limits of surface water ponding within parking lots.
- N. Trash racks as applicable.
- O. Location and widths of easements.
- P. Location and type of pumps, if applicable.
- Q. Stormwater treatment/quality control facility location, length, width, slopes, and cross-section.

- R. Planting and seeding requirements with establishment procedure (construction sequence) for water quantity or quality systems.
- S. Finish floor elevations of all buildings.
- T. Indicate separation from any pipe, infiltration trench, open ditch, water quality and stormwater facilities to any property line, structure and obstruction.
- U. For ponds, provide: landscaping, fencing, empty power conduits for potential future aeration system, maintenance access, critical water surface elevations, and other items, such as walls and liners.
- V. Number the storm drain structures. (Numbers will be provided by the City prior to final plan approval.)
- W. Low Impact Development (LID) facility location, length, width, slopes, and cross-section.

### **3.04.07 Utility Plan Sheets**

The plan set shall include an overall utility plan that shows the private connections to the public water and sanitary sewer systems, together with the storm drainage system and proposed landscaping, and any required extensions of the public water and sanitary sewer systems. The overall utility plan shall be clearly visible on one to two plan sheets, with a maximum scale of 1"=100'.

The scale of the plans may need to be increased to improve visibility. Callouts shall be shown in both the plan and profile views (e.g., manholes, catch basins, etc.).

The more detailed Utility sheet(s) shall have the applicable items identified below:

#### **Water**

Water system design shall be in accordance with Chapter 7 – Water Facilities, and shall include the following items:

- A. Water pipe and fitting size, location, and type of material.
- B. Details of connections to existing water mains.
- C. Valve size, locations and type.
- D. Fire hydrants locations.
- E. Air/vacuum relief valve and blow-off locations.
- F. Pressure reducing stations and associated valves, vaults and by-pass piping as required.
- G. Concrete blocking, mechanical, or restrained joint pipe support.
- H. Water main, water meter, and fire hydrant easements.
- I. Meter size and service line size and location.
- J. Irrigation meter size and service line size location.
- K. Proposed fire line, FDC line, and PIV locations. Provide a note with the underground fire line noting that a separate fire permit will be required for the underground fire line between the connection to the public water main to the building.



- L. Backflow prevention assembly and detector check meter size, type and location.
- M. For buildings requiring fire sprinklers, the fire sprinkler notes shall be shown on the plan, as shown in Appendix B of this chapter.
- N. Table or call out showing physical separation in feet between water lines and other utilities at crossings, when a profile is not required.
- O. Cross connection control notes included in Appendix B of this Chapter.
- P. For plat or road projects, provide unique stationing down the center of the road with the appropriate offset at all water main appurtenances. For all other projects, provide unique stationing down the center of the water main.

## **Sanitary Sewer**

Sanitary sewer system design shall be in accordance with Chapter 8 – Sanitary Sewer Facilities, and include the following items:

- A. Sanitary sewer pipe size, locations, type of material, and stationing.
- B. Location of manholes. Indicate type of manhole, stationing, offset, and number manholes consecutively. During the City review process, manhole numbers shall be assigned by the City to be incorporated into the next submittal.
- C. Indicate knockouts in manholes for future connections.
- D. The direction of sewage flow shall be indicated with an arrow at the manhole. Proposed sewer shall have solid arrowheads while existing pipe and manholes shall be shown in ghost or screened lines with the arrowhead and manhole not filled. The location of the frame and cover on the manhole, positioned over the widest part of the shelf and not over a flow channel, shall be shown.
- E. Drop manholes, if approved, are to be detailed on the plans.
- F. Length, slope, type and class of material, and inverts for side sewers.
- G. Stationing for side sewers from downstream manholes.
- H. Connection of a side sewer to the City's sanitary sewer pipe shall be indicated with a tee.
- I. Locations of sanitary sewer cleanouts.
- J. Locations of sanitary sewer easements.
- K. Clearly define right-of-way and adjacent property lines. Parcel numbers for all lots adjacent to the improvements shall be indicated, with existing or proposed finished floor elevations.
- L. Floor drains, drains from other covered areas potentially subject to pollutants, and wash areas within parking lots shall be connected to the sanitary sewer through an approved oil/water separator.

### 3.04.08 Utility Profile Sheet

Utility Profiles are to be included on the associated utility plan sheet(s) with plan view above the profile view and corresponding unique stationing. All existing and proposed parallel and crossing utilities shall be shown on the profile.

#### Storm Drainage

Profiles shall be created for all designed storm systems. These profiles are to include the following items where applicable:

- A. Public storm drainage located within the street right-of-way shall be shown on the street profile. See **Section 3.04.09**.
- B. Public storm drainage located in an easement shall have separate profiles.
- C. Structure size, location, type, station, invert elevation, type of lid or grate, rim elevation, stationing and offset.
- D. Pipe size, type of material, slope (ft./ft.), and lineal footage.
- E. Utility crossings shall identify size and type of utilities involved.
- F. Ditches where applicable, size, type and slope.
- G. Existing and finished grade along pipe centerline.
- H. Connections to existing structures.

#### Water

Profiles shall be provided for all public water systems, including on-site systems and systems within the street/City right of way and easements, These profiles shall include the following items where applicable:

- A. Water line located within the street right-of-way shall be shown on the street profile. See **Section 3.04.09**.
- B. Pipe size, type of material, lineal footage, cover, stationing and offset.
- C. Utility crossings shall identify size and type of utility involved.
- D. Existing and finished grade along pipe centerline.
- E. Connections to existing mains and fittings.
- F. Label fittings and valves include blocking.

#### Sanitary Sewer

A profile will be required for all public sanitary sewer mains. These profiles are to include the following items where applicable:

- A. Sanitary sewer located within the street right-of-way shall be shown on the street profile. See **Section 3.04.09**.
- C. Structure size, location, type, station, invert elevations, type of lid, rim elevation, stationing and offset.
- D. Pipe size, type of material, slope (ft./ft.), and lineal footage.

- E. Utility crossings shall identify size and type of utility involved.
- F. Existing and finished grade along pipe centerline.
- G. Connections to existing structures.
- H. Side sewer locations, stationing and offset.

### **3.04.09 Public Street Plan and Profile Sheet**

Whenever a project includes construction within a public street, excluding utility connections, both a plan and a profile shall be included in the plan set. The Public Street Plan and Profile sheet(s), when required, shall have the applicable items identified below:

#### **Plan View**

The plan view shall include the following items where applicable:

- A. Plan views shall be drawn at a 1" = 20' scale.
- B. Existing and proposed rights-of-way.
- C. Existing and proposed contours and elevations.
- D. Existing and proposed street names.
- E. Existing and proposed centerline bearing and distance.
- F. Existing and proposed signs and traffic control devices.
- G. Existing and proposed storm drainage systems.
- H. Existing and proposed sewers and water mains. Identify crossings and minimum distances between utilities.
- I. Horizontal curves.
- J. Horizontal stationing.
- K. Location of curbs, sidewalks, wheelchair ramps, and driveways (by station).
- L. Locations of monuments at all centerline intersections, cul-de-sacs, PCs, and PTs by station.
- M. Street luminaires, conduit for streetlights, traffic signals, and traffic signal loop detectors located within the vicinity of the project.
- N. Mailbox types and locations for plats and short plats. Submit to postmaster for approval.
- O. Address any horizontal utility conflicts in plan.
- P. Street landscaping, if required.
- Q. Construction limits.
- R. Slope excavation and/or embankment limits.
- S. All proposed and existing underground and overhead utilities shall be shown and labeled on the plan in gray scale. The locations shall be coordinated and approved through the appropriate utility purveyor.

## Profile

The profile shall include the following items where applicable:

- A. Profiles shall be drawn using 1" = 20' horizontal and 1" = 2' vertical scales.
- B. Existing and proposed centerline road grade.
- C. Existing and proposed storm drainage systems.
- D. Existing and proposed sewers and water mains (use ghost lines). Identify crossings and minimum distances between utilities.
- C. Finish grade elevations every 50 feet and every 25 feet for vertical curves along design centerlines.
- D. Vertical curve information in profile section.
- E. Address vertical utility conflicts in profile.

## Intersections

Intersection plans shall be 20 scale drawings in conformance with **Figure 3-1** below:

**Figure 3-1 Intersection Plan Sheet Requirements**

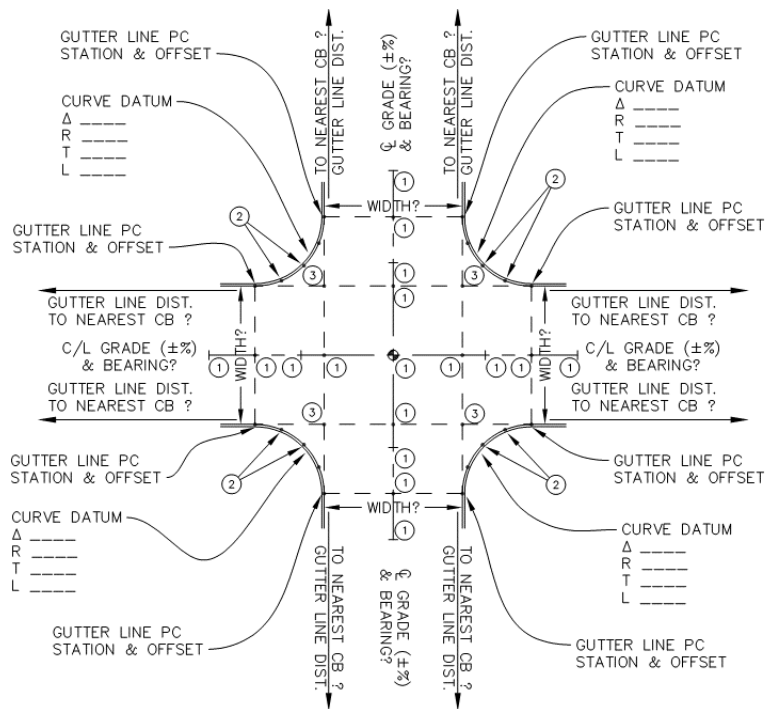

### NOTES:

- A. LABEL INTERSECTION & STATIONING. SHOW FINISH ELEVATIONS AT:
  - ① CENTER LINES, AS SHOWN.
  - ② GUTTER LINE RADII: PC'S, PT'S,  $\frac{1}{4}$  POINTS, & HIGH/LOW POINTS.
  - ③ GUTTER LINE PI'S.
- B. IF RADIUS POINT FOR R.O.W. & GUTTER LINE DIFFER, PROVIDE DATA OF R.O.W. CURVE.
- C. LABEL CENTERLINE INTERSECTION EQUATION STATIONS (IF APPLICABLE).

## Typical Roadway Sections

Typical roadway sections shall show pavement depths, widths and materials, cross-slopes of pavement (%), centerline, dimensioned right-of-way lines, curb and gutter, ditches, embankment and excavation slopes (1:1), walls, etc. Typical sections will be labeled within identified station ranges.

## Striping and Signing

Provide maximum 40 scale plans per these Standards, WSDOT and MUTCD, including lane markers, pavement markings, and signing.

## Signalization

Provide 20 scale separate detailed signalization plan per City of Auburn Standards, including poles, bases, conduits, and traffic loops.

### Signal Plan Sheet

1. The plan sheet shall conform to the following requirements:
  - a. For areas that require greater detail (such as the corner that has the controller), a blown-up detail may be necessary at a 1"=10' scale.
  - b. All proposed signal equipment, including signal poles, mast arms, heads, signs, junction boxes, conduit, loops, controller, and service cabinet shall be shown as bold.
  - c. All existing and proposed right-of-way information shall be shown and labeled on the plan, including easements needed for signal equipment. The line type shall be different for easements and right-of-way.
  - d. All proposed curb, sidewalk, proposed striping, and existing curb/striping (to remain) information shall be shown on the plan in gray scale (screened back).
  - e. Sight triangle lines shall be shown on plans in gray scale.
  - f. All proposed and existing underground and overhead utilities shall be shown and labeled on the plan in gray scale.
  - g. Provide on the plan signal construction notes as shown in Appendix B of this chapter.
2. Construction notes shall contain, but not be limited to:
  - a. Signal pole and foundation installation (including pole type, mast arm length, and installation of items on the pole).
  - b. Controller cabinet and foundation installation.
  - d. Coordination of utility removal/relocation.
  - e. Coordination of connection of power, and power source type.
  - f. Interconnect connection to other signals.
  - g. Removal of existing signal and/or street light equipment.
3. Displays: The plan sheet shall include the following displays:

- a. Phase diagram display.
  - b. Signal display showing signal layout of all vehicle signal heads and pedestrian heads.
4. Detection: The plan sheet shall include:
- a. Stop bar, intermediate and advanced loop location and numbering.
  - b. Pedestrian push button location.
  - c. Preemption detection location and numbering.
5. Signal Poles and Associated Equipment: The plan sheet shall contain, but not be limited to:
- a. Signal Pole Locations and Numbering: The locations shall be called out by the major arterial station and offset.
  - b. Signal head location and numbering.
  - c. Pedestrian head location and numbering.
6. Controller and Service Location:
- At least one corner of the controller/service foundation shall be called out by the major arterial station and offset. The footprint of the foundation shall be shown on the plans with the controller and service cabinets oriented on the foundation as they would be placed in the field. If the information required to show all the controller/service conduit connections and foundation footprint makes the plan too cluttered, a blown-up detail of the corner containing this information is needed at a 1"=10' scale.
7. Power Source Location:
- The location of the power source shall be identified on the plans.
8. Wire Schedule:
- a. A wire schedule table shall include run numbers, conduit size, wire type, and comments.
  - b. Comments shall include, but not be limited to, number of twisted loop pairs for runs between the detection loops and adjacent junction box, identification of spare conduits, conduits utilized only by interconnect or illumination, and power cables.
  - c. For designs that include modifications to an existing signal, all existing wire runs affected by the design shall be shown on the wire schedule.
9. Junction box type and approximate location.
10. Signing:
- a. Signs shall be shown on all mast arms. Signs that are post mounted but are signal related (such as a "signal ahead" sign) shall be shown on the signal plan.
  - b. A sign display shall be shown on the plan with the MUTCD sign designation, dimensions, and lettering type for all signs.
  - c. Indicate removal of existing stop signs after signal is in operation.
  - d. Installation of "New Signal Ahead" or "Signal Revision Ahead" signs.
11. Other Illumination:

- a. Proposed illumination that will use the signal service cabinet, but is located outside the four quadrants of the intersection, shall be shown as proposed on a separate illumination plan sheet. On the signal plan sheet, the illumination shall be shown as gray scale and labeled as “proposed illumination, see illumination plans.” However, once the illumination enters the quadrants of the intersection (i.e., when it is using the same junction box as the signal equipment), it shall be shown as proposed on the signal plan and gray scale on the illumination plan.
- b. Indicate the circuit that street lights are on.

#### Wire Diagram Plan

In general, the wire diagram shall include the following:

1. All signal heads, pedestrian heads, pedestrian push buttons, luminaires, preemption detectors, loops, and junction boxes drawn in schematic forms.
2. All termination points in the controller cabinet. The wire diagram shall include every termination point the controller will have, including those that may not be used for this particular signal design.
3. All wiring associated with the items above, as well as the wiring for interconnect. The wire diagram shall show how these items are connected to the controller.
4. Location of wire splices.
5. All termination numbering at each end of each wire. For example, the 5-conductor cable connecting a signal head to the controller shall have the termination numbering called out at the signal head and in the termination points in the controller.
6. All wire colors at each end of the wire.
7. A call out to each wire run noting the number and type of each wire.
8. Intersection schematic with a north arrow showing approach phase.
9. Pole, signal head, pedestrian head, preemption detection, and loops shall be numbered on the wire diagram.

#### Pole Schedule Plan

The pole schedule shall include the following:

1. The pole schedule shall include a signal standard detail chart.
2. The pole schedule shall include pole orientation attachment and base detail, pole foundation detail, and signal standard detail.

## **Illumination**

Street Light Plans shall be labeled as Street Light Plans, and shall be prepared, stamped, signed and dated by a professional engineer.

Street Light Plans will include references to all applicable City of Auburn Standard Details and/or Washington State Department of Transportation (WSDOT) Standard Plans, or copies of other specific details applicable to the project shall be shown on the plans.

Plans should show any proposed street trees and underground utilities in the background.

Street Light Plans shall be provided on separate and uncluttered sheets that do not show unrelated street, utilities, or on-site improvements. Street Light Plans shall be drawn to a maximum engineer's scale of 1" = 40'.

Street Light Plans shall at a minimum include the following applicable items for new or existing street lighting system:

- A. Lighting schedule with the following information in a table format:
  - 1. Luminaire make and model
  - 2. Lamp/Ballast type
  - 3. Lamp wattage
  - 4. Uniformity Ratio
  - 5. Minimum Light Level
  - 6. Average Maintained Light Level
  - 7. Light standard type
  - 8. Mounting height (ft.)
  - 9. Bracket or davit arm length (ft.)
  - 10. Light distribution pattern
  - 11. Luminaire spacing distance (ft.)
  - 12. Light standard locations by station and offset from the centerline of the street to the center of the light standard. Show all existing street lights for a distance of 500 feet in both directions from the limits of the project site, including both sides of the street(s) and in medians.
  
- B. Wiring/Conduit schedule with the following information in a table format:
  - 1. Circuit number
  - 2. Conduit size, material, and purpose (street lighting, traffic signal interconnect, spares, etc.).
  
- C. Location of points of service (the PSE connection or service location and the new or existing City Electrical Service Cabinet(s)).
  
- D. Location of junction boxes. Indicate junction box type and purpose (lighting, traffic signal, etc.).



- E. Existing topography, including but not limited to the location of driveways, street trees (including species), street intersections, overhead utilities (including maximum and minimum heights), underground utilities (including sizes), medians, curb, and lane widths (pavement markings).

### **Streetscape**

Provide information on planting of the public landscape strips along the street frontage. Information shall include the following:

- A. Type and size of trees.
- B. Tree spacing.
- C. Type of ground cover.
- D. Root control/barrier.
- E. Irrigation if applicable.
- F. Show all proposed and existing surface features and underground utilities.

### **Other Features**

Include locations of any other feature including mailboxes and bus stops. Any mailbox placement that requires approval from the postmaster shall include the Postmaster approval block B-2 as shown in Appendix A of this chapter.

### **3.04.10 Site and Landscape Plan Sheet**

The site and landscape sheets (separate plans may be more appropriate), when required, shall have the following applicable items:

- A. Demonstrate conformance with Chapters 18.50, "LANDSCAPING AND SCREENING" and 18.52 "OFF-STREET PARKING AND LOADING" of ACC.
- B. Label name, classification, and boundary of adjacent streets both public and private.
- C. Pavement types with unique hatching.
- D. Site signage and striping
- E. The boundaries and dimensions of site.
- F. Show and label any easements.
- G. Show and label any critical areas and buffers affecting the site.
- H. The location of on-site buildings and their eaves or protrusions (decks, porches, covered entries, etc.) and other site features (generators, compressors, retaining walls, fuel tanks, etc.).
- I. The location of on-site parking stalls, drive aisles, and loading/unloading areas and required fire lanes with dimensions.
- J. The location and size of landscape areas (measured to the inside of curbs).
- K. Landscape area calculations as required by ACC 18.50.040, "Landscape development standards"

- L. The species (common and scientific name), condition (bare root, balled & bur lapped) or containerized) and size of planting materials (shown within a “planting schedule”).
- M. Notation of which species are native to, or adapted to the Pacific Northwest (minimum 50%)
- N. Site preparation specifications (removal of construction debris, soil amendment, fertilizer, etc.)
- O. The location and type of non-vegetated groundcovers such as rock, mulch, etc.
- P. The location, size, and proposed screening of outdoor storage areas and dumpster/refuse areas.
- Q. The location, species, and size (diameter at DBH) of all existing trees and measures to protect them.
- R. Show all proposed and existing surface features and underground and above-ground utilities affecting the site.
- S. Landscaping notes, including:
  - i. Plant materials list substitutions requiring city approval and possibly “as-built plans”.
  - ii. Planting notes (e.g., when to remove tree stakes).
  - iii. Soil quality and installation.
  - iv. Maintenance after installation.
- T. Site furnishings such as light posts, bike racks, benches, trash cans, and shopping cart racks.

#### **3.04.11 Site Irrigation Plan sheet**

The site irrigation sheets, when required, shall have the following applicable items:

- A. The connection point to the City system, together with the water meter size.
- B. The size, location, and type of the backflow prevention.
- C. The proposed layout of the irrigation system.
- D. Be consistent with the site’s building and landscaping plans.
- E. Show the existing and/or proposed location of all parcel lines.

#### **3.04.12 Critical Area Restoration/Mitigation**

A critical area restoration or mitigation sheet, when required, shall include the items as required by the City pursuant to chapter 16.10 and 15.68 of the Auburn City Code.

#### **3.04.13 Phasing Plans**

Applications that propose to complete projects in phases shall submit a phasing plan which incorporates all required conditions of approval and details infrastructure improvements and sequencing of the phases. Prior to occupancy of any buildings within a phased project, complete construction, inspection, acceptance, and transfer of ownership to the City via Bill of Sale as well as recorded easements are required for all public utilities

(water, sewer, & storm) serving the building and public road improvements/right of way dedications must be complete. If the private utilities are proposed to be constructed in phases, the points of connection between phases and how the future phases will be constructed without affecting the operation of the previous phases must be shown.

Phasing plans are subject to approval by the City Engineer and Building Official and shall include the following information:

1. Illustrative maps for each proposed phase which clearly mark in heavy lines the boundaries of the subject phase, label the phase alphabetically (to avoid confusion with lot numbers), and depict roads, lots, infrastructure, easements, dedications and open space which are included within the subject phase. The plan shall also illustrate those proposed improvements which mitigate impacts associated with the unbuilt portions of the project which are not located within the boundaries of the subject phase. Previously established phases, including roads, lots, infrastructure, easements, dedications, and open space, should be shown on the map shaded or gray-scaled. All phasing maps shall be drawn at the same scale.

2. A narrative description or table which describes each phase and its associated improvements. In addition, the narrative or table shall demonstrate that each phase would comprise a "stand-alone" development which, should no subsequent phases be constructed, would meet or exceed City standards and all other conditions of approval. The narrative should also describe the proposed timeline for completion of the entire project. The narrative must address emergency access, street improvements, and alternative construction access.

## Appendix A – Approval Blocks

### Sample Engineering Approval Block (B-1):

PROJECT REF: _____
THESE PLANS ARE APPROVED FOR CONFORMANCE WITH THE CITY OF AUBURN'S ENGINEERING REQUIREMENTS.
DEV. REVIEW ENGINEER: _____
DATE APPROVED: _____

### Sample Postmaster Approval Block (B-2):

CITY OF AUBURN POSTMASTER APPROVAL
APPROVED BY: _____
TITLE/POSITION: _____
DATE APPROVED: _____

### Sample Engineering Approval Block (B-3):

<b>CITY OF AUBURN APPROVALS</b>	
THIS PLAN SET FOR PROJECT _____, SHEETS ___ TO ___ ARE APPROVED FOR CONSTRUCTION BY:	
_____, P.E., CITY ENGINEER: _____	DATE: _____
_____, DEV. REVIEW ENGINEER: _____	DATE: _____
_____, PLANNER: _____	DATE: _____

## Appendix B – Standard Notes

The following General Notes shall apply to Development projects:

### GENERAL NOTES

1. CONSTRUCTION SHALL CONFORM TO THE CITY OF AUBURN'S ENGINEERING DESIGN AND CONSTRUCTION STANDARDS, EXCEPT AS OTHERWISE APPROVED BY DEVIATION, AND BE IN ACCORDANCE WITH THE APPROVED PLANS. ANY CHANGES FROM THE APPROVED PLAN WILL REQUIRE APPROVAL FROM THE OWNER, ENGINEER OF RECORD, AND THE CITY.
2. ALL WORKMANSHIP AND MATERIALS SHALL CONFORM TO THE "WASHINGTON STATE DEPARTMENT OF TRANSPORTATION (WSDOT) STANDARD SPECIFICATIONS FOR ROAD, BRIDGE, AND MUNICIPAL CONSTRUCTION (CURRENT EDITION)," EXCEPT WHERE SUPPLEMENTED OR MODIFIED BY THE CITY'S CONSTRUCTION STANDARDS MANUAL. THE ABOVE DOCUMENTS SHALL BE AVAILABLE AT THE JOB SITE DURING CONSTRUCTION.
3. A PRE-CONSTRUCTION MEETING SHALL BE REQUIRED PRIOR TO THE START OF ALL CONSTRUCTION. CONTACT THE PUBLIC WORKS DEPARTMENT AT 253-931-3010, TO SCHEDULE A MEETING.
4. UNLESS STATED OTHERWISE, LOCATIONS SHOWN FOR EXISTING UTILITIES ARE APPROXIMATE. THE CONTRACTOR IS CAUTIONED THAT OVERHEAD UTILITY LINES MAY NOT BE SHOWN ON THE DRAWINGS. IT SHALL BE THE CONTRACTOR'S RESPONSIBILITY TO DETERMINE THE TRUE ELEVATIONS AND LOCATIONS OF ALL UNDERGROUND UTILITIES AND THE EXTENT OF ANY HAZARD CREATED BY OVERHEAD UTILITY LINES. IDENTIFICATION, LOCATION, MARKING, AND RESPONSIBILITY FOR UNDERGROUND FACILITIES OR UTILITIES, IS GOVERNED BY THE PROVISIONS OF CHAPTER 19.122 REVISED CODE OF WASHINGTON (RCW). PRIOR TO STARTING CONSTRUCTION, THE CONTRACTOR SHALL CALL ONE-CALL (811) FOR UTILITY LOCATIONS (WATER, SANITARY SEWER, STORM SEWER, GAS, POWER, TELEPHONE, AND CABLE).
5. IF A PROPOSED ROUTE IS NOT INCLUDED ON THESE PLANS, A PROPOSED ROUTE AND SCHEDULE FOR HAULING MATERIAL TO THE SITE SHALL BE SUBMITTED TO THE CITY FOR APPROVAL PRIOR TO THE START OF CONSTRUCTION. IF THE CITY BELIEVES THAT THE PROPOSED HAUL ROUTE WILL ADVERSELY IMPACT THE STREET NETWORK, A SEPA AMENDMENT MAY BE REQUIRED TO EVALUATE THE IMPACTS AND DETERMINE MITIGATION REQUIREMENTS BEFORE BEGINNING WORK. HAULING MAY BE LIMITED TO APPROPRIATE OFF-PEAK HOURS OR ALTERNATIVE ROUTES, AS DETERMINED BY THE CITY.
6. THE CONTRACTOR SHALL BE RESPONSIBLE FOR PUBLIC SAFETY ON AND AROUND THE PROJECT. PRIOR TO THE START OF WORK, ALL METHODS AND EQUIPMENT USED FOR TRAFFIC CONTROL AND STREET MAINTENANCE SHALL BE SUBMITTED TO THE CITY FOR APPROVAL. CONTRACTORS AND THEIR SURETY SHALL BE LIABLE FOR INJURIES AND DAMAGES TO PERSONS AND PROPERTY SUFFERED BECAUSE OF CONTRACTORS OPERATIONS OR NEGLIGENCE CONNECTED WITH THEM.
7. ALL CONSTRUCTION SURVEYING FOR EXTENSIONS OF PUBLIC FACILITIES SHALL BE DONE UNDER THE DIRECTION OF A WASHINGTON LICENSED LAND SURVEYOR OR A WASHINGTON LICENSED PROFESSIONAL CIVIL ENGINEER.

8. CERTIFIED DRAWINGS ARE REQUIRED PRIOR TO PROJECT ACCEPTANCE.  
REFER TO THE CITY'S "DEVELOPMENT RECORD CONSTRUCTION DOCUMENT"  
HANDOUT.

## **Appendix B – Standard Notes (continued)**

### **GRADING AND EROSION CONTROL NOTES**

1. WITHIN THE CITY OF AUBURN, ALL REQUIRED SEDIMENTATION AND EROSION CONTROL FACILITIES INDICATED ON THE PLANS MUST BE CONSTRUCTED AND IN OPERATION PRIOR TO LAND CLEARING AND/OR OTHER CONSTRUCTION ACTIVITIES. THESE FACILITIES SHALL BE MAINTAINED AND UPGRADED, IF NECESSARY, TO INSURE THAT SEDIMENT-LADEN WATER AND STORM DRAINAGE RUNOFF DOES NOT IMPACT THE ADJACENT PROPERTIES, NATURAL DRAINAGE WAYS, OR THE EXISTING CITY STORM DRAINAGE SYSTEM.
2. THE SOURCES FOR ALL MATERIAL IMPORTED TO THE SITE SHALL BE APPROVED BY THE CITY.
3. THE STORM DRAINAGE DETENTION (RETENTION IF INFILTRATION SYSTEM IS USED), SEDIMENTATION AND EROSION CONTROL FACILITIES DEPICTED ON THE APPROVED DRAWINGS ARE INTENDED TO BE MINIMUM REQUIREMENTS TO MEET ANTICIPATED SITE CONDITIONS. ADDITIONAL DRAINAGE AND EROSION CONTROL FACILITIES MAY BE REQUIRED AS SITUATIONS WARRANT DURING CONSTRUCTION. THE IMPLEMENTATION, MAINTENANCE, REPLACEMENT AND ADDITIONS TO THESE CONTROL SYSTEMS SHALL BE THE RESPONSIBILITY OF THE PERMITEE.
4. THE TEMPORARY EROSION CONTROL FACILITIES, INCLUDING ALL PERIMETER CONTROLS AND THE DETENTION (RETENTION IF INFILTRATION SYSTEM IS USED), CONTROL PONDS, SHALL REMAIN IN PLACE UNTIL FINAL SITE CONSTRUCTION IS COMPLETED. AFTER CITY APPROVAL, THE CONTRACTOR WILL BE RESPONSIBLE FOR REMOVING ALL TEMPORARY FACILITIES.
5. THE CONTRACTOR WILL BE REQUIRED TO WATER THE SITE, AS NECESSARY, TO REDUCE DUST EMISSIONS AS A RESULT OF CONSTRUCTION ACTIVITY.
6. NO TRACKING IN THE ROADWAY IS ALLOWED. IF SEDIMENT IS TRACKED ONTO THE ROAD, THE ROAD SHALL BE THOROUGHLY AND IMMEDIATELY CLEANED BY SHOVELING OR PICKUP SWEEPING. TRANSPORT SEDIMENT TO A CONTROLLED SEDIMENT DISPOSAL AREA. KEEP STREETS CLEAN AT ALL TIMES.
7. ALL AREAS OF ACTIVE EARTHWORK WHICH HAVE THE POTENTIAL FOR EROSION AND SEDIMENTATION IMPACTS ON ADJACENT PROPERTIES, NATURAL DRAINAGE WAYS, OR THE EXISTING CITY STORM DRAINAGE SYSTEM MUST BE STABILIZED ACCORDING TO THE FOLLOWING SCHEDULE: FROM MAY 1 TO SEPTEMBER 30, AREAS AT FINAL GRADE AND THOSE THAT ARE SCHEDULE TO REMAIN UN-WORKED FOR MORE THAN SEVEN (7) DAYS SHALL BE STABILIZED. FROM OCTOBER 1 TO APRIL 30 EARTHWORK ACTIVITIES SHALL BE CONDUCTED IN STAGES IN ORDER TO MINIMIZE SOIL EXPOSURE. EXPOSED SOILS THAT WILL REMAIN UN-WORKED FOR MORE THAN TWO (2) DAYS SHALL BE STABILIZED IMMEDIATELY.

## **Appendix B – Standard Notes (continued)**

### **FIRE SPRINKLER SYSTEMS NOTES**

SPRINKLER SYSTEMS SHALL MEET CITY OF AUBURN STANDARD 7.01.6.2 AND THE FOLLOWING REQUIREMENTS:

1. PROPOSED FIRE LINE TO BE SIZED BY A FIRE PROTECTION ENGINEER.
2. BACKFLOW PROTECTION IS REQUIRED ON FIRE SPRINKLER LINES
3. A SEPARATE DETAILED PLAN OF THE UNDERGROUND FIRE SPRINKLER SUPPLY LINE SHALL BE APPROVED BY THE FIRE MARSHAL AND INSTALLED BY A WASHINGTON STATE CERTIFIED LEVEL “U” CONTRACTOR IN ACCORDANCE WITH WAC 212-80-010.
4. A POST INDICATOR VALVE SHALL BE INSTALLED ON THE FIRE SPRINKLER SUPPLY LINE TO ISOLATE THE SYSTEM FROM THE CITY’S WATER SYSTEM WHEN REQUIRED FOR REPAIR.
5. BLOCKING, PIPING, AND RODDING DETAILS SHALL BE PROVIDED WITHIN THE SUBMITTAL.
6. APPROVAL OF THE CIVIL PLANS DOES NOT APPROVE THE INSTALLATION OF THE SPRINKLER SYSTEM SUPPLY PIPING.

### **CROSS CONNECTION CONTROL NOTES**

CROSS CONNECTION CONTROL SHALL MEET THE FOLLOWING REQUIREMENTS:

1. ALL BACKFLOW PREVENTION ASSEMBLIES SHALL BE INSTALLED IN A MANNER THAT WILL ALLOW PROPER OPERATION, AND IN-LINE TESTING AND MAINTENANCE.
2. A BACKFLOW ASSEMBLY PERMIT IS REQUIRED FOR ALL ASSEMBLIES INSTALLED WITHIN THE CITY OF AUBURN, AND/OR THE CITY’S WATER DISTRIBUTION SYSTEM.
3. BACKFLOW ASSEMBLIES MUST BE ON THE CURRENT WASHINGTON STATE DEPARTMENT OF HEALTH – BACKFLOW ASSEMBLIES APPROVED FOR INSTALLATION LIST.
4. BACKFLOW ASSEMBLIES MUST BE TESTED BY A STATE CERTIFIED BACKFLOW ASSEMBLY TESTER, AND INSPECTED AND APPROVED BY A CITY OF AUBURN CROSS CONNECTION CONTROL SPECIALIST.
5. UPON RECEIVING APPROPRIATE FEE PAYMENTS AND VERIFYING THAT REDUCED PRESSURE BACKFLOW ASSEMBLY (RPBA) HAS BEEN INSTALLED (NOT BY CITY), THE CITY WILL INSTALL THE DOMESTIC METER INSIDE THE DOMESTIC METER BOX. THE PASSING TEST REPORT FOR THE RPBA MUST



BE RECEIVED BY THE CITY WITHIN 72 HOURS OF THE INSTALLATION OF THE DOMESTIC METER.

6. UPON RECEIVING APPROPRIATE FEE PAYMENTS AND VERIFYING THAT DOUBLE CHECK VAULT ASSEMBLY (DCVA) HAS BEEN INSTALLED (NOT BY CITY), THE CITY WILL INSTALL THE IRRIGATION METER INSIDE THE IRRIGATION METER BOX. THE PASSING TEST REPORT FOR THE DCVA MUST BE RECEIVED BY THE CITY WITHIN 72 HOURS OF THE INSTALLATION OF THE IRRIGATION METER.
7. DOUBLE CHECK VALVE ASSEMBLY (DCVA, NOT BY CITY) TO BE INSTALLED BY THE CONTRACTOR ONTO THE FIRE SERVICE LINE, THE PASSING TEST REPORT FOR THE DCVA MUST BE RECEIVED BY THE CITY WITHIN 72 HOURS OF THE CONNECTION OF THE BUILDING FIRE SERVICE LINE TO THE CITY MAIN.

### **SIGNAL CONSTRUCTION NOTES**

1. THE LOCATION OF ALL CONDUIT, JUNCTION BOXES, AND CABINETS SHOWN ON THIS PLAN ARE FOR GRAPHIC PRESENTATION ONLY AND FINAL LOCATION SHALL BE DETERMINED BY THE ENGINEER.
2. ALL TRAFFIC SIGNAL AND PEDESTRIAN HEADS AND PUSH BUTTONS SHALL BE SECURELY AND COMPLETELY COVERED WHILE SIGNAL IS NOT IN OPERATION.
3. ALL CONDUCTORS FOR SIGNAL HEADS, LOOPS, PEDESTRIAN HEADS, PUSH BUTTONS AND STREETLIGHTS SHALL BE LABELED IN EACH JUNCTION BOX.

## Appendix C – Deviations

### Plan Sheet Deviation Call-Out:

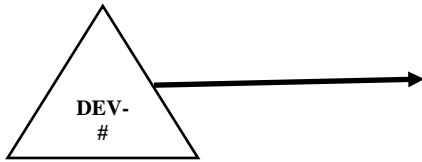

- Leader arrow points to deviation location.
- DEV-# is the City assigned deviation number

### Plan Sheet Deviation Description:

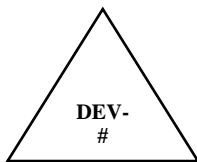

SECTION X.X.X OF THE \_\_\_\_\_, APPROVED \_\_\_\_\_.

- Description is included with the construction notes on the plan sheet where the deviation is located.
- Description references the Chapter, Section, and Subsection Number (where applicable) of the Engineering Design or Construction Standards where the standard that is being deviated from is
- Includes approval date in mm/dd/yyyy format.
- Includes a brief description why the deviation allowed as provided by the City.

## Appendix D – Survey Standards

### COA Horizontal Datum & Basis of Bearing Information (Ref RCW 58.09.060; WAC 332-130-050)

The City of Auburn's horizontal datum is NAD83(1991), Washington State Plane Coordinates, North Zone, 4601

Basis of Bearings: Provide the observed or calculated bearing between two existing, recoverable monuments, along with NAD83(1991) coordinates and an accurate physical description of the monuments, including type, size and date visited. Clearly depict on the survey map ties to the project site from the basis of bearings.

For Example:

#### **HORIZONTAL DATUM**

**NAD83(1991), Washington State Plane Coordinates, North Zone, 4601**

#### **Basis of Bearings:**

**The monumented centerline of 17th Street NE from COA Mon 509-036 at the intersection of Auburn Way North to COA Mon 509-010 at the intersection of I Street NE = S 89°04'04" E**

**COA Mon 509-036**

**COA Mon 509-010**

**N: 121004.23**

**N: 120994.54**

**E: 1296131.38**

**E: 1296726.97**

**DESC: Encased brass disk with "X"**

**DESC: Encased brass disk with punch**

### COA Vertical Datum & Benchmark Information (Ref WAC 332-130-050)

The City's vertical datum is NAVD88

Provide Project Benchmark information that includes a physical description of the benchmark, date visited and elevation. Clearly depict the project benchmark on the survey map. If the project benchmark is located a significant distance from the project site, it is recommended that a site benchmark be established in close proximity to the project site and also clearly labeled and depicted on the survey map.

For example:

#### **VERTICAL DATUM**

**NAV88**

**Project Benchmark: COA 509-036 (BM B19)**

**Brass disk in concrete in monument case at SI of Auburn Way North & 17th St NE**

**Elevation = 65.99 (NAVD88)**

## Appendix D – Survey Standards (continued)

### -- Existing Conditions – Topographic Map Checklist (Ref. WAC 332-130-145)

Topographic elements on maps—Requirements. For the purposes of this section, topographic elements consist of information shown on a map which depicts the horizontal and vertical positions of natural and/or fabricated features and existing terrain surfaces.

The following requirements shall apply to maps that include topographic elements, prepared by professionals registered under chapters 18.43 and 18.210 RCW.

The following elements must be included on every map that includes topographic elements:

<input type="checkbox"/>	1	Name, stamp and dated signature of professional land surveyor licensed in State of Washington who prepared the map drawing.
<input type="checkbox"/>	2	Contact information including company name, address, email address and phone number
<input type="checkbox"/>	3	Location of site, including address (if applicable), tax parcel number, and quarter, quarter section, township and range
<input type="checkbox"/>	4	Legend of symbols used. Symbol size matches in legend and in depiction.
<input type="checkbox"/>	5	North Arrow.
<input type="checkbox"/>	6	Map scale and graphic scale bar
<input type="checkbox"/>	7	Legal description of the subject real property
<input type="checkbox"/>	8	<b>Horizontal datum:</b> NAD83(1991), Washington State Plane Coordinates (WSPC), North Zone.
<input type="checkbox"/>	9	<b>Basis of Bearings statement:</b> Provide the observed or calculated bearing between two existing, recoverable monuments, along with NAD83(1991) coordinates and an accurate physical description of the monuments, including type, size and date visited. Clearly depict on the survey map ties to the project site from the basis of bearings.
<input type="checkbox"/>	10	<b>Vertical Datum:</b> NAVD88
<input type="checkbox"/>	11	<b>Basis of elevations statement:</b> a listing of reference benchmarks shall be included on the topographic map including elevations, descriptions and date visited.
<input type="checkbox"/>	12	Listing of project benchmarks established on-site or in vicinity including descriptions and elevations clearly labeled and depicted in the map.
<input type="checkbox"/>	13	Statement of horizontal control accuracy per WAC 332-130
<input type="checkbox"/>	14	Clearly depict and label contours and intervals.
<input type="checkbox"/>	15	Statement of elevation and contour accuracy.
<input type="checkbox"/>	16	Statement on intended use and limitations of topographic elements shown on the map.
<input type="checkbox"/>	17	Statement on the source of boundary information and methods used to relate area mapped to said boundaries. Provide indexing information for all record documents referenced.
<input type="checkbox"/>	18	Statement specifying the source of all utilities depicted on the map (such as "surface markings", "as-built drawings", "potholing" or "field measurements")
<input type="checkbox"/>	19	Statement specifying the accuracy of all utilities depicted on the map (such as "locations of underground utilities shown hereon are based upon field measurements" or "...based upon City of Auburn Project CP1099 As-Built drawings")
<input type="checkbox"/>	20	Statement specifying the scope of work between the project owner and professional land surveyor regarding the comprehensiveness, exclusions, and limits of the utility investigations leading to utility depictions.

## Appendix E – Minor Grading Permit Criteria

- Project Thresholds
  - Except as approved otherwise by the City Engineer, only projects meeting all of the following criteria qualify for a Minor Grading Permit Submittal:
    - The project is located on a single family parcel with an existing home, and does not include the construction of a new single family home or the project is a remodel/tenant improvement on a non-residential project with all work occurring inside the existing building that is not exempt from a grading permit per ACC 15.74
    - The project does not include the construction of public improvements and right of way dedications.
    - Project does not construct dwelling units, excluding accessory dwelling units.
    - Project does not construct walls that are over 8-feet tall and less than 10 feet from the property line.
    - Combined cut and fill earthwork is less than 50 cubic yards. Earthwork is calculated by adding cut and fill quantities together, no net earthwork volume.
    - Grading activities do not change existing drainage patterns and are not within 10-feet of the property line.
    - Project disturbs less than 1 acre of area.
    - Total area of new and/or replaced hard surfaces is less than 5,000 SF.
    - The project is a remodel/tenant improvement on a non-residential project that is inside of a building that is not exempt from a grading permit per ACC 15.74.
- Submittal Requirements
  - Projects meeting the above thresholds are required to submit the following when applying for a Minor Grading Permit:
    - A completed Civil Application and Owner Authorization Form from the Civil Site Improvement Packet. The Civil Plan Review Checklist found in the packet is not required for a Minor 1 Grading Permit.
    - Application Fee per the adopted fee schedule
    - A neat, legible site plan showing the existing and proposed site improvements, storm drainage system, adjacent public rights of way, site address, parcel number, and owner's name.
    - A Stormwater Site Plan Short Form. A sample Short Form Stormwater Site Plan Report is available on the City's Website on the [Public Works Publications & Forms](#) page. A Stormwater Site Plan Short Form is not required for remodel/tenant improvement projects listed above.
    - A Construction Stormwater Pollution Prevention Plan Short Form. A sample Construction Stormwater Pollution Prevention Plan Short Form is available on the City's Website on the [Public Works Publications & Forms](#) page.
    - Additional reports or supporting documentation as requested by the City Engineer At the discretion of the City Engineer, the project plans may require a stamp and signature by a Professional Engineer.
    -

All other projects requiring a Grading Permit shall submit a Grading Permit per the Civil Site Improvement Packet.

## Appendix F – AutoCAD Layers Standards

- FORMAT: Digital files shall be provided in AutoCAD 2019 (2018 format) or older “.DWG” format. All support files required to display or plot the files in the same manner as developed shall be delivered along with these files. Scanned hard copy drawings using raster-to-vector conversion will not be an acceptable digital format. AutoCAD files shall be prepared in accordance with the Layers Standard included in Appendix D, Chapter 3 of the City of Auburn Engineering Design Standards.
- MEDIA: Digital files shall be submitted via an electronic delivery method acceptable to the City of Auburn. Disks and/or drives shall be clearly labeled with the project name, drawing name(s), name of the drafting/engineering company or individual(s), date, and appropriate City of Auburn identifiers (e.g., BLD#, FAC#, etc.).
- SPATIAL REFERENCES: Drawings will be at full scale, and shall be accurately located in State Plane Coordinates Washington North Zone, 4601, and tied to two existing and recoverable City of Auburn horizontal control monuments. Datum will be noted on the drawings. All drawings shall use survey control datum NAD 83/91 for horizontal control and NAVD 88 for vertical control.
- CONTENTS: The digital drawing files shall include, at a minimum, the following:
  - The overall project site plan showing new and existing construction, property lines, easements, and survey references.
  - New and existing water, sanitary sewer, and storm drainage elements showing location, size, and material of utility lines and structures.
  - Separate layering showing existing impervious surfaces, new impervious surfaces, and annotation on the area of each in square foot units. Layer features for impervious surfaces shall be created from closed polylines to aid in verifying calculations of impervious surface area.
- DOCUMENTATION: Final recorded changes shall be clearly reflected when Certified Record Construction Drawings are processed. Proposed features shall use the layer names and descriptions given below. Any layers included that do not meet the descriptions below shall be accompanied by a detailed list of layers and layer descriptions.

## Appendix F – AutoCAD Layers Standards (continued)

<b>Proposed Feature</b>	<b>AutoCAD Layer Name</b>
Buildings - Polygon	C-SITE-BLDG-OTLN
Commercial Fiber - Polyline	C-COMM-FIBR
Conduit: Polyline	C-COMM-CDNT
Curbs - TBC - Polyline	C-ROAD-TBCV
Curbs - Gutter - Polyline	C-ROAD-GTTR
Curbs - Flow (TFC) - Polyline	C-ROAD-FLOW
Driveways - Polyline	C-PVMT-CONC-DRWY
Easements - Polygon	C-PROP-ESMT
Fences - Polyline	C-SITE-FENC
Power Service Cabinets - Point	C-POWR-VALT
Sewer Cleanouts - Point	C-SSWR-SSCO
Sewer Laterals - Polyline	C-SSWR-LATR
Sewer Mains: Polyline	C-SSWR-PIPE
Sewer Manholes - Point	C-SSWR-MHOL
Sidewalks - Polygon	C-PVMT-CONC-SDWK
Storm Catch Basins - Point	C-STRM-STRC
Storm Culverts - Polyline	C-STRM-CULV
Storm Manholes - Point	C-STRM-MHOL
Storm Pipes - Polyline	C-STRM-PIPE
Street Lights - Point	C-POWR-LITE
Street Painted Lines - Polyline	C-ROAD-MRKG
Traffic Signal Cabinets - Point	T-POWR-SGNL-CBNT
Traffic Signal Poles - Point	T-POWR-SGNL-POLE
Traffic Signs - Point	C-SITE-SIGN
Traffic Vaults	T-POWR-VALT
Vegetation - Polygon	C-SITE-VEGE
Trees - Point	C-SITE-TREE
Utility Poles - Point	C-POWR-POLE
Water Auxiliary Equipment - Point	C-WATR-FTTG
Water Hydrants - Point	C-WATR-FHYD
Water Laterals - Polyline	C-WATR-LATR
Water Mains - Polyline	C-WATR-PIPE
Water Meters - Point	C-WATR-METR
Water Valves - Point	C-WATR-VALV
Wetlands - Polygon	C-WETL-DELN

## **4 Report Preparation Requirements**

### **4.00 Preface**

This chapter describes how technical engineering reports are to be laid out to meet City requirements and provide a format that is easy to follow and understand. Reports need to meet these basic standards in order to move through the review process in an efficient manner.

### **4.01 General Requirements**

The following general requirements shall be met for all technical engineering reports being submitted for review and approval:

- A. All reports and calculations shall be prepared, stamped, signed, and dated by a professional engineer.
- B. The topographic map prepared for the project shall be prepared, stamped, signed, and dated by a professional land surveyor.
- C. All reports and calculations shall be neat, uncluttered, legible, and in conformance with the requirements herein.
- D. All engineering reports shall be bound with the civil engineer's stamp clearly visible.
- E. Reports shall reference City Standards as necessary.
- F. All reports shall be provided in electronic format (PDF).

### **4.02 Report Types and Requirements**

The following are basic types of reports submitted as supporting project information. Depending on the complexity or simplicity of the project and its location, the amount of detail, and the number and types of reports required will be subject to change. The examples given are the typical reports required for a standard project, there may be other reports required that are specific to a particular project.

#### **4.02.01 Geotechnical Reports**

Geotechnical reports are required to support the design and construction of various facilities as specified in the Auburn City Code, these design standards, the SWMM, the Engineering Construction Standards, and other documents. The geotechnical report format shall include (at a minimum) the following applicable items:

- A. Title page including project name and address.
- B. General information, which includes existing site conditions.
- C. Site history including any prior grading.
- D. Subsurface soil information and conditions including seasonal high groundwater and impermeable layer elevations. Seasonal groundwater levels shall be determined using groundwater monitoring well(s) and shall be required where consideration of groundwater levels is a design consideration.
- E. Soil log information and locations of explorations.



- F. Soil characteristics including suitability for fill and compaction requirements.
- G. Slope stability analysis.
- H. Seismic hazards.
- I. Geological hazard areas as defined in the City's Code (ACC 16.10).
- J. Site plan showing the topography and proposed structures and paving.
- K. Grading information including depth of cuts and recommended slopes.
- L. Recommendations on temporary erosion and sediment control.
- M. Conclusions and recommendations for foundations.
- N. Appendix with test pit and boring logs.
- O. Information on infiltration rates for use in designing low impact design facilities, retention ponds and infiltration trenches.
- P. California Bearing Ratio (CBR) information for pavement design.
- Q. Additional requirements for geotechnical reports are included in Volume 1 of the SWMM.

#### **4.02.02 Stormwater Site Plan Report**

The Stormwater Site Plan Report shall contain the information as noted in Appendix J of Volume I of the SWMM.

#### **4.02.03 Critical Area Report**

- A. Title Page including project name, contact information for property owner, applicant, and preparer, a description of the proposal, site address, and the parcel number.
- B. Identify all local, state, and other critical area related permits/approvals required for the proposal.
- C. Indicate accuracy of the report.
- D. Documentation of field work (such as field data sheets, and rating worksheets in the case of wetlands).
- E. Description of methodologies used in the study.
- F. Identify and characterize all critical areas including wetlands, streams, water bodies, buffers, regulatory floodplain, wildlife habitat, groundwater protection areas, critical erosion hazard areas, landslide hazard areas, seismic hazard and volcanic hazard areas on or adjacent (within 300 feet of the project boundaries) to the proposed project area.
- G. Provide location and critical area rating/classification (if applicable) and required buffers based on a professional survey. Provide the classification according to ACC 16.10.080, "Classification and rating of critical areas" and identify the classification according to other agency standards for which permits/approvals are required.
- H. A description of proposed actions, including estimated area of impacts to the critical area(s), and the impact to buffer(s).

- I. An assessment of probable temporary, permanent, and cumulative impacts to the critical area(s) and buffer(s).
- J. Mitigation measures proposed and relationship to applicable mitigation standards.
- K. Scaled site plan.
- L. Qualifications of person(s) preparing the report.

#### **4.02.04 Traffic Impact Analysis**

- A. Title Page including project name and address.
- B. Executive Summary.
- C. Table of Contents.
- D. Introduction consisting of a description of the project, location, site plans with access to city streets, circulation network, land use and zoning, phasing plan, project developer and contact person, reference other studies.
- E. Traffic Analysis to include assumptions, existing and projected traffic volumes, project trip generations, trip distribution, level of service (LOS), and warrant analysis.
- F. Appendix with all calculations.
- G. Information as specified in **Section 10.16** of these design standards.

#### **4.02.05 Construction Stormwater Pollution Prevention Plan (SWPPP)**

See **Section 5.01.03** of these design standards and Chapter 2 of Volume 2 of the SWMM.

#### **4.02.06 Other Reports**

Other reports may be required on a site-specific basis. The specific information required in these reports shall be determined during the SEPA process or by the department requiring the report. These reports shall include the following basic items:

- A. Title page including project name and address.
- B. General information, which includes existing site conditions.
- C. Site plan showing the topography, proposed structures, and paving.
- D. Conclusions and recommendations.
- E. Appendix with collected field information.

# 5 TESC, Clearing and Grading

## 5.00 Preface

The design of Temporary Erosion and Sediment Control (TESC) clearing and grading plans shall conform to the requirements herein.

Compliance with these standards does not alleviate the design engineer from using sound professional engineering practices. The design criteria contained herein are the minimum acceptable under standard conditions. Special conditions may require more stringent requirements that will be addressed during the plan review process.

The purpose of these requirements is to provide the design criteria necessary to preserve the City of Auburn's water courses; minimize surface and ground water quality degradation; control sedimentation in creeks, streams, rivers, ponds, lakes, and other water bodies; protect adjacent and downstream property owners from increased runoff rates which could cause erosion and flooding; and ensure the safety and stability of City of Auburn's roads and rights-of-way.

## 5.01 TESC Design Criteria

### 5.01.01 Temporary Erosion and Sediment Control (TESC)

TESC design requirements shall meet design criteria requirements as identified in Volume II of the City of Auburn Surface Water Management Manual (SWMM), and follow City of Auburn grading requirements.

All TESC measures regardless of design and implementation must meet the latest Nephelometric Turbidity Units (NTU) test requirements. The City may conduct tests and if the applicable limits are not met, the project will be halted until such time as it is brought into compliance.

### 5.01.02 Temporary Sedimentation Systems

The temporary sedimentation facilities (ponds and traps) shall be defined as the active storage available a minimum of 1 foot above the seasonal high ground water.

### 5.01.03 Construction SWPPP

Any project with exposed soil meeting the requirements of the Chapter 2 of Volume 2 of the SWMM shall prepare a Stormwater Pollution Prevention Plan (SWPPP). The plan shall follow the SWPPP Template (available at the Dept. of Ecology's website) or City of Auburn Short Form (where approved by the City) from the SWMM.

## 5.02 Land Clearing

For land clearing requirements see ACC 15.74. Plans for Land Clearing shall following the requirements for Grading.

## 5.03 Grading

### 5.03.01 Purpose

The following section establishes the requirements for grading. These requirements do not supersede nor are they intended to be inconsistent with any landscaping requirement

established by the Zoning Ordinance or other City action. A grading permit shall be required except for the situations described in ACC 15.74.050 or as listed below:

- A. The City Engineer or designee, may approve the broadcasting of less than 500 cubic yards of topsoil, peat, sawdust, mulch, bark, chips, or solid nutrients used for landscaping or soil conditioning on a lot, tract or parcel of land during any 24-month period, provided the finished depth does not increase the grade from the existing grade by more than 8 inches.

### **5.03.02 Excavations**

- A. Cut slopes shall generally be constructed no steeper than two horizontal to one vertical (2:1). The City may approve steeper slopes after a geotechnical analysis is performed justifying a steeper slope.
- B. Cut slopes shall be stabilized by terracing, cat tracking, jute mat, grass sod, hydro-seeding, or by other planting or surfacing materials acceptable to the City.
- C. The City may also require geotechnical analysis for the following:
  - Slopes with sub-surface or surface water flows.
  - In areas of questionable soils conditions.
  - Where the length of the slope requires terracing.
  - In other situations where slope stability could be in question.

### **5.03.03 Fills**

- A. Fill slopes shall generally be constructed no steeper than two horizontal to one vertical (2:1). The City may approve steeper slopes after a geotechnical analysis is performed justifying a steeper slope. Temporary fills for preloading of building pads may use a slope one and one half horizontal to one vertical (1.5:1).
- B. Fill slopes shall be stabilized by terracing, cat tracking, jute mat, grass sod, hydroseeding, or by other planting or surfacing materials acceptable to the City.
- C. The City may also require geotechnical analysis for the following:
  - Slopes with surface water flows.
  - In areas of questionable soils conditions.
  - Where the length of the slope requires terracing.
  - In other situations where slope stability could be in question.
- D. A minimum horizontal setback of 5 feet shall be provided between the bottom of any fill placement and the top of the bank of any defined drainage channel.
- E. When filling a site, particular care shall be taken to prevent impeding the existing upstream surface drainage flow.

### **Preparation for Fill**

Prior to any fill being placed, all vegetation, topsoil and other unsuitable material shall be removed unless dictated otherwise by the geotechnical engineer. Where fill is being

placed on existing slopes of greater than five horizontal to one vertical (5:1), a geotechnical analysis shall be performed.

## **Compaction**

Fill material shall be placed in lifts of no more than 12 inches and compacted to 90% or greater of the maximum dry density as determined by ASTM D1557 Modified Proctor or as directed by the geotechnical engineer.

## **Slope Easement**

Slope easements adjacent to the right-of-way may be required for maintenance of cut or fill slopes and drainage facilities. Easement shall be from the catch point plus a minimum of 5 feet, as determined by the City.

### **5.04 Retaining Walls**

Retaining walls that support/retain land outside the public right-of-way will be located outside the public right-of-way and be owned and maintained by the owner of the land the retaining wall is supporting. This is typically the case when the public right-of-way is below the grade of the adjacent property. These walls are considered private walls and subject to ACC Title 15. Walls supporting private property that are built with City capital projects may be considered public or private walls, to be determined by the City Engineer on a case-by-case basis with general preference that the walls be privately owned and maintained.

Retaining walls that support/retain the public right-of-way will be located within the public right-of-way and be owned and maintained by the City. This is typically the case when the public right-of-way is above the grade of the adjacent property. These walls are considered public walls.

Retaining wall systems with a vertical difference of 30-inches or greater require protective fencing along the top edge for safety.

Public retaining walls require dedication of easement(s) of sufficient terms and area, in the opinion of the City Engineer, to allow for access, maintenance, repair, removal, and reconstruction of the wall. The minimum easement width for this purpose is 10 feet centered on the wall face and a minimum of 5 feet beyond any and all structural elements behind the wall. Walls 10 feet and taller require a minimum 15 foot wide easement and maintenance road along the wall base that is fenced and gated.

#### **5.04.01 Underdrains**

Underdrains are required for all retaining walls over 4 feet in height (i.e., concrete walls, MSE walls, soil nail walls, block retaining walls, etc.).

A minimum 6-inch diameter perforated or slotted drainpipe shall be placed in a shallow excavated trench located along the inside edge of the keyway. The pipe shall be bedded on and surrounded by "Gravel Backfill for Drains" (WSDOT/APWA 9-03.12(4)) to a minimum height of 18 inches above the bottom of the pipe. A filter fabric shall surround the gravel backfill and shall have a minimum of 1 foot overlap along the top surface of the gravel. The perforated pipe shall be connected to a storm drain system or to an acceptable outfall.

#### **5.04.02 Rock Walls**

Rock Walls may be used for containment of cut slopes or fill embankment up to a maximum height of 8 feet. Rock Walls over 4 feet in height, surcharged, or in areas of questionable soil stability will require an engineered design. The engineered design shall include a soils investigation and report by a geotechnical engineer and structural calculations to support the rockery design.

Rock Size Categories include:

Two-man rocks (200 - 600 pounds) 18" - 28" average diameter.

Three-man rocks (601 - 2000 pounds) 28" - 36" average diameter.

Four man rocks (2001 - 4000 pounds) 36" - 48" average diameter.

The rock material shall be as rectangular as possible. No stone shall be used that does not extend through the wall. The quarried rock shall be hard, sound, durable, and free from weathered portions, seams, cracks, and other defects. The rock density shall be a minimum of 160 pounds per cubic foot, measured accordingly to WSDOT test method 107 (Bulk Specific Gravity - S.S.D. basis).

#### **5.04.03 Block Retaining Walls**

Block retaining walls, (e.g., Keystone, Allan Block, Ecology Block) may be used for containment of cut slopes or fill embankment. Block retaining walls over 4 feet in height, surcharged, or in areas of questionable soil stability will require an engineered design. The engineered design shall include a soils investigation and report by a geotechnical engineer and structural calculations to support the block wall design.

Blocks used for retaining walls shall be in good condition and structurally sound; cracked and/or broken blocks are not acceptable. Unless designed as a gravity wall (ecology blocks), block walls over 4 feet in height shall employ geo-grid type material to increase the structural stability of the wall.

#### **5.04.04 Reinforced Concrete Walls**

Reinforced concrete walls or cast-in-place concrete walls may be used for containment of cut slopes or fill embankment. Concrete retaining walls over 4 feet in height, surcharged, or in areas of questionable soil stability will require an engineered design. The engineered design shall include a soils investigation and report by a geotechnical engineer and structural calculations to support the concrete wall design.

A minimum 3,000-psi structural reinforced concrete shall be used in the design of concrete retaining walls.

#### **5.04.05 Mechanically Stabilized Earth Walls (MSE Walls)**

MSE walls may be used in conjunction with other retaining walls or as a stand-alone application when constructing fill slopes. MSE walls will require an engineered design. The engineered design shall include a soils investigation and report by a geotechnical engineer and structural calculations to support the MSE wall design.

MSE walls shall employ well-draining structural soil compacted to the geotechnical engineer's specifications.

## 5.05 Construction Sequence

### 5.05.01 Requirements

A construction sequence is intended to ensure that the timing and installation of storm drainage and erosion control measures are in place prior to activities that may cause erosion to occur. The following elements are to be included in a construction sequence:

- A. Establishment of clearing and grading limits.
- B. Construction of temporary construction entrance.
- C. Construction of perimeter ditches, filter fabric fences, and other erosion control devices as shown.
- D. Construction of storm drainage control (applicant to be specific) facilities including emergency overflow as applicable.
- E. Construction of ditches and swales as necessary to direct all surface water to the storm drainage control (be specific) facilities as clearing and grading progress. Prevention of uncontrolled surface water being allowed to leave the site at any time during the grading operations.
- F. Establishment of at what point grading activities can begin, which is usually only after all perimeter drainage and erosion control measures are in place.
- G. For sites with a final development plan, the following shall also be addressed when applicable:
  1. Installation of on-site permanent storm drainage, sanitary sewer, and water facilities.
  2. Site paving.
  3. Indicate at what point building construction may begin.
  4. A description of how to transition from the temporary to permanent storm facilities.
  5. The possibilities of any phased construction.
  6. Any off-site public or private improvements including the general timing and duration.
  7. The removal of all TESC measures at project completion upon City approval.
- H. The TESC plan sheet shall also include a construction sequence element which clearly identifies the timing and methodology required to:
  1. Contain areas of active earthwork to prevent uncontrolled discharge of storm drainage
  2. Minimize erosion and the extent and time soils are exposed on-site.
  3. Prevent tracking of sediment onto City streets.
  4. Protect permanent on-site and off-site storm drainage systems.

## 6 Storm Drainage Facilities

### 6.00 Preface

The purpose of these requirements is to provide the design criteria necessary to preserve the City of Auburn's water courses; to minimize surface and ground water quality degradation; to control the sedimentation in creeks, streams, rivers, ponds, lakes, and other water bodies; to protect adjacent and downstream property owners from increased runoff rates, which could cause erosion and flooding; to ensure the safety of City of Auburn's roads and rights-of-way; and to decrease drainage-related damage to both public and private property. The standards also are required to control runoff from development, redevelopment and construction sites to comply with the Western Washington Phase II Municipal Stormwater Permit issued by the State of Washington Department of Ecology.

Compliance with these standards does not alleviate the design engineer from using sound professional engineering practices. The design criteria contained herein are the minimum acceptable under standard conditions. Special conditions may require more stringent requirements that will be addressed during the plan review process.

The City's Comprehensive Storm Drainage Plan establishes drainage basins and design parameters used to estimate future line hydraulic capacities. Anyone proposing to extend or modify the City's storm drainage system should contact the Public Works Department for information on line sizes and locations. Developer-constructed public storm drainage improvements shall be installed by means of a Facility Extension Agreement (FAC) between the developer and the City. The Community Development Department can provide information on this agreement as well as applicable permit and connection fee estimates.

### 6.01 SWMM Requirements

All requests for developing a storm drainage system must comply with the City of Auburn Surface Water Management Manual (SWMM). The City has adopted the 2014 Department of Ecology Stormwater Management Manual for Western Washington and the City of Auburn Supplemental Manual as the SWMM. The Supplemental Manual provides guidance for applying specific sections of the Ecology document within the City of Auburn. All references to the City's SWMM include both documents. The City's Supplemental Manual can be found utilizing the following hyperlink:

[Supplemental Manual](#)

Subject to exceptions and criteria as defined in the SWMM, ALL new or re-development project must use Low Impact Development (LID) principles, if feasible.

Storm drainage system design is guided by the 10 Minimum Requirements for Stormwater Management, listed below. The applicability of the Minimum Requirements is based on project size and the total new and/or replaced hard surfaces created by the project. It is recommended that the Minimum Requirements, especially LID, are considered at the beginning of project design to insure that the required elements can be included in the project. The SWMM also addresses modeling standards and design criteria for conveyance, storage, treatment facilities, and other drainage system structures.

The SWMM is divided into five volumes that address different aspects of storm drainage system design. These volumes and the key components for design and application submittal are:

- **Volume I – Minimum Technical Requirements and Site Planning**
  - Project thresholds for application of the 10 Minimum Requirements for Stormwater Management on new development and redevelopment projects.



- The 10 Minimum Requirements (MR) for Stormwater Management are:
  - MR #1: Preparation of Stormwater Site Plans
  - MR #2: Construction Stormwater Pollution Prevention
  - MR #3: Source Control of Pollution
  - MR #4: Preservation of Natural Drainage Systems and Outfalls
  - MR #5: On-Site Stormwater Management
  - MR #6: Runoff Treatment
  - MR #7: Flow Control
  - MR #8: Wetlands Protection
  - MR #9: Operations and Maintenance
  - MR #10: Off-Site Analysis and Mitigation (Supplemental Manual)
- Guidance for developing Stormwater Site Plan (SSP) reports to satisfy MR #1.
- SSP report submittal requirements checklist (Supplemental Manual).
- Glossary of terms used throughout the SWMM.
- Summary of infeasibility criteria for MR #5 List Option BMPs (Supplemental Manual).
- City of Auburn access requirements for stormwater facilities (Supplemental Manual).
- Information on areas within the City that have special development requirements (Supplemental Manual).
- **Volume II – Construction Stormwater Pollution Prevention**
  - Information on the 13 Elements of Construction Stormwater Pollution Prevention required by MR #2.
  - Guidance on developing a Construction Stormwater Pollution Prevention Plan (SWPPP) that satisfies MR #2 and meets the City's submittal requirements.
  - Best Management Practices (BMPs) for controlling construction runoff and preventing construction related stormwater pollution.
  - A SWPPP Short Form that may be used on projects meeting the size requirements provided (Supplemental Manual).
- **Volume III – Hydrologic Analysis and Flow Control BMPs**
  - Minimum computational standards and modeling requirements for hydraulic and hydrologic design and submittal.
  - Design requirements for flow control facilities, including detention ponds, vaults and control structures, to comply with MR #7.
  - Additional City of Auburn design requirements for flow control facilities (Supplemental Manual).
  - Conventional conveyance system design requirements for pipes, catch basins, channels, and other conveyance structures.
  - Information on the City of Auburn Design Storm (Supplemental Manual).
  - Site design criteria for infiltration facilities, including procedures for conducting a Pilot Infiltration Test to determine soil infiltration rates.

- **Volume IV – Source Control BMPs**

- Operational and Source Control BMPs for activities that will be performed on the site after completion of construction. These BMPs are required where applicable for projects that must meet MR #3.
- Additional City of Auburn source control BMPs (Supplemental Manual).

- **Volume V – Runoff Treatment BMPs**

- Guidance on selecting treatment facilities to comply with MR #6.
- Maintenance standards for storm drainage facilities.
- Design criteria for treatment facilities and on-site stormwater management facilities that are used to meet MR #5, MR #6, and MR #7.
- Additional City of Auburn design requirements for treatment facilities, including bioretention and permeable pavement facilities (Supplemental Manual).

## 6.02 Additional Requirements

The following additional requirements supersede and replace any conflicting requirements specified in the SWMM.

### 6.02.01 Storm Drainage Pipes and Structures

Storm drainage pipes and manholes shall meet the requirements specified in Chapter 8, Sanitary Sewer Facilities, and Volume III, Chapter 3 of the SWMM, with the following additions:

A. Catch Basins and Inlets shall be constructed per the following:

Catch Basin/Inlet Type	Construction Standard	Notes
Catch Basin Type I	WSDOT Standard Plan B-5.20	15-inch diameter max. pipe size, 5-foot max. depth to invert.
Catch Basin Type II	WSDOT Standard Plan B-10.20	See Standard Detail.
Concrete Inlet	WSDOT Standard Plan B-25.60	15-inch diameter max. pipe size, 5-foot max. depth to invert., only utilized for single pipe and where a full depth catch basin is not feasible.
Cement Concrete Curb and Gutter Pan	WSDOT Standard Plan F-10.16	Utilized along curb and gutter sections.
Rectangular Vaned Grate	WSDOT Standard Plan B-30.30	Utilized for all catch basins along curb and gutter sections unless in a sag condition.
Rectangular Frame (Reversible)	WSDOT Standard Plan B-30.10	Utilized for all catch basins.
Combination Inlet	WSDOT Standard Plan B-25.20	Utilized in sag conditions along curb and gutter.

B. Allowable storm sewer pipes shall be as listed in Chapter 8, Section 8.01.3 with the following additional type allowed:

Storm Sewer Pipe Type	Construction Standard	Notes
Polypropylene Culvert and Storm Sewer Pipe	Section 9-05.24(1) of the WSDOT Standard Specifications	Allowed for full range of depths and sizes

# 7 Water Facilities

## 7.00 Preface

The design and construction of Public Water Facilities shall conform to the State of Washington Department of Health (DOH) Design Standards for Group A Public Water Systems, the Standard Specifications of the American Water Works Association (AWWA), and the most recent published and adopted edition of the Uniform Plumbing Code (UPC), unless modified herein.

Compliance with these standards does not alleviate the design engineer from using sound professional engineering practices. The design criteria contained herein are the minimum acceptable under standard conditions. Special conditions may require more stringent requirements that will be addressed during the plan review process. Contact the City of Auburn Engineering Services for specific requirements for the design of pump stations, wells, reservoirs, treatment systems, and other special facilities.

The design criteria used to estimate future line capacities are established in the City's Comprehensive Water Plan. Anyone proposing to extend or modify the City's water system should contact the Public Works Department for information. Applicants needing to construct public water improvements shall enter into a Developer Public Facility Extension Agreement (FAC) with the City. The City's Permit Center can provide information on this agreement as well as applicable permit and connection fee estimates.

## 7.01 Water Mains

Unless otherwise approved by the City Engineer, all water mains shall be constructed using Special Class 52 Cement Lined Ductile Iron Pipe having standard asphaltic coating on the exterior and cement-mortar lining on the interior. The list of acceptable valves, fittings, and other appurtenances for water facility construction is subject to change as new and improved components become available. Refer to the City of Auburn's Construction Standards manual (latest edition) for the most current information on these requirements.

The design of water mains shall meet the requirements in the following subsections:

### 7.01.01 Water Main Sizing

Public water mains shall be sized using the following criteria:

- A. New water mains shall be sized, as indicated in the City's current Comprehensive Water Plan. For lines not specified in the plan, the mains shall be sized as described in this subsection.
- B. Water mains in single-family residential areas shall be a minimum of 8 inches in diameter.
- C. Water mains in multi-family residential and non-residential areas shall be a minimum of 12 inches in diameter. Onsite water main loops, with no possibility of future extension as determined by the City Engineer, serving two or less fire hydrants with no fire line connection may be reduced to a minimum diameter of 8 inches.
- D. Water mains shall be looped to provide a minimum of two separate connection points to the existing water system, with sufficient valves so that water can be

delivered through either connection point independent of the other, except where determined to be not feasible by the City Engineer. Such looping will provide more reliable service and water movement through the distribution system.

- E. Water mains shall be sized under fire flow conditions, so that flow velocity shall not exceed 8 feet per second in distribution mains or 5 feet per second in transmission mains.
- F. Exceptions to the minimum diameter allowed may be made in small cul-de-sacs and in areas where looping of a main is determined to be not feasible. In these cases, the main may be a minimum of 4 inches in diameter after the last fire hydrant connection.

If a conflict arises between two or more of these criteria, the water main shall be designed using the largest pipe diameter required.

### **7.01.02 Water Main Location**

- A. Water mains shall be installed with no less than 42 inches and no more than 72 inches of finished cover.
- B. Water mains shall be located in the public right-of-way or within a public water utility easement. Water mains located in the public right-of-way shall meet the requirements of **Section 9.03**.
- C. Water mains shall be located a minimum horizontal distance of 10 feet from buildings and sanitary sewer mains and a minimum horizontal distance of 5 feet from all other utilities. The minimum separation distance is measured from the outside wall of each pipe.
- D. At crossings between utilities, water mains shall be located a minimum vertical distance of 18 inches above sanitary sewer mains and a minimum vertical distance of 12 inches from all other underground utilities, and shall be in conformance with the applicable sections of the State of Washington Department of Ecology's "Criteria for Sewage Works Design" manual (DOE Manual) unless modified herein.
- E. Water mains shall be extended through the full width of the property to be served. Where deemed appropriate by the City Engineer, provisions shall be made for looping all existing and new dead-end mains associated with the project. If, at the time of project approval this is not feasible, an easement shall be provided and the main extended to the adjacent property line or right-of-way for future looping of the dead-end main.
- F. When the potential exists to serve adjacent properties, water mains shall extend through the property being served, through the shared driveway or access tract serving the property(s), or across the entire length of the lot frontage as necessary to serve the adjacent properties, as determined by the City.

### **7.01.03 Water Main Fittings**

- A. Blowoffs (**See City of Auburn Standard Detail W-03 or W-04**) are required on dead-end water mains with a diameter of 6 inches or less; hydrants are required for dead-end mains over 6 inches in diameter. Blowoffs shall also be installed at the low point of a depressed "sag" section of a water main, except where a fire hydrant is installed within 50 feet of said area or on a short segment (20 feet

or less) where the water main dips under other utilities. Blowoffs shall be placed in a level clear area within the right-of-way or easement, be located as close to the main as possible, and be easily accessible to the City.

- B. Combination air/vacuum release valves (**See City of Auburn Standard Detail W-02**) are required at high points in water mains when an abrupt vertical change in pipe elevation exceeds one pipe diameter, except where fire hydrants are installed within 50 feet of said area. Combination air release valves shall be placed within a level clear area within the right-of-way or easement and be easily accessible to the City.
- C. All bends shall have mechanical or flanged joints and concrete thrust blocking (**See City of Auburn Standard Detail W-01**). The City may require restrained joints in lieu of thrust blocking in special conditions.
- D. Tees shall have flanged joints unless there is no valve against the Tee, in which case the Tee may be flanged or mechanical. Tees shall include concrete thrust blocking (**See City of Auburn Standard Detail W-01**). When connecting to an existing public water main, a tapping tee and valve may be used, if only a single valve is needed at the tee, or unless otherwise approved or required by the City.
- E. Tapping tees are not allowed on commercial fire lines or other water taps needing uninterruptible service; a cut-in tee or installed tee is required.
- F. Size-on-size taps are not allowed unless authorized in writing by the City Engineer or designee.
- G. The maximum allowable deflection per joint for ductile iron water mains shall be half of the maximum joint deflection specified by the pipe manufacturer or 4 degrees, whichever is less.

## 7.02 Water Services

**See City of Auburn Standard Details W-06, W-13 through W-16a, and W-20.**

The City owns and shall maintain the water service line from the main to the meter, the meter and setter, the meter radio, the meter tailpiece, and the meter box. The property owner owns and shall maintain the tailpiece connection fitting, shut-off valve, service line after the shut-off valve, and other facilities such as pressure reducing valves, pumps, or backflow prevention assemblies behind the meter.

For fire sprinkler connections, City ownership and maintenance responsibilities include and cease at the valve installed at the point of connection between the main and the fire service line.

### 7.02.01 Domestic Services

Domestic Water Services are defined as any service that connects directly to plumbing within a structure and is used for drinking, cooking, washing, and other standard uses of potable water. Domestic water services shall meet the following requirements:

- A. Each parcel receiving water service shall have its own meter. Non-single family developments with multiple buildings on a single parcel shall have a meter for each building unless otherwise authorized in writing by the City Engineer or designee.
- B. Installation of corporation stops, water services, and meters shall be per City of Auburn Standard Details. The City may, at the City's option, install services from public water mains to the meter in existing rights-of-way and easements. The

developer/contractor will install and/or replace all applicable services when installing new water mains required for the project. The City will furnish and install the meter for services of 2 inches and smaller.

- C. Water meters of 3 inches and larger will be purchased from the City and installed by the developer/contractor under City observation. Where vaults are required, the vault roof shall contain a 2-inch port for remote read device.
- D. Water meters shall be located in a level unobstructed area not subject to vehicular parking or travel, and as close to the City main as possible with the distance not to exceed 50 feet.
- E. Residential sites shall have water meters placed in landscape strips within the right-of-way, set 2 inches above the finished grade including landscaping and mulch. If no areas are available in the right-of-way that are not subject to vehicle parking or traffic, water meters may be placed outside the right-of-way in public water utility easements.
- F. Commercial and industrial sites shall have meters located near driveway entrances within the right-of-way or within public water utility easements in landscape islands located near access driveways when placement in right-of-way is not practical.
- G. Meters may not be placed within sidewalks or pedestrian travel pathways except in cases where obstructions prevent the meter box from being placed behind the sidewalk or in a landscape strip (where a landscape strip is present). In such conditions, the meter box shall be placed in the sidewalk such that the edge of the meter box closest to the roadway is no closer than 6-inches to the adjacent edge of sidewalk. A minimum of 2 inches shall be maintained between meters boxes.
- H. The water service diameter and meter size shall be sized per Tables 610.3 and 610.4 of the current Uniform Plumbing Code and, upon request by the City, supporting documentation of the meter size selection provided to the City. The length of the service between the meter and the structure shall not exceed 300 feet.
- I. When installing multiple services to a public main, a minimum spacing of 2 feet shall be used between corporation stops, a minimum spacing of 5 feet shall be used between corporation stops and tapping tees, and a minimum spacing of 5 feet shall be used between tapping tees on existing ductile iron mains and 10 feet on all other types of existing water main materials.
- J. Domestic water services shall be connected to a looped distribution main unless otherwise approved by the City.

## **7.02.02 Other Services**

Irrigation and other non-domestic water services shall meet all the above requirements as well as the following:

- A. An Irrigation meter shall be installed in cases where water is used for landscape purposes by non-single family customers and does not enter the sanitary sewer system.
- B. For fire sprinkler service line requirements, see **Section 7.06.02**.
- C. Cross connection control devices shall be installed per **Section 7.04**.

### **7.02.03 Service Abandonment**

Services shall be abandoned when properties are redeveloped and existing meters will no longer be used. The following actions are required after removal of the meter:

- A. Obtain the necessary permits (e.g., for work in the right-of-way, for meter abandonment)
- B. Shut off the corporation stop at the main.
- C. Disconnect the service line from the corporation stop.
- D. Remove the meter box.
- E. Restore the roadway or other surface(s) disturbed by construction activities (e.g., trench patch/overlay)

## **7.03 Water Valves**

Water valves shall be as specified in the Construction Standards and meet the following additional requirements:

**See City of Auburn Standard Details W-17 through W-19 for valve box and extensions**

### **7.03.01 Water Valve Sizing**

Water valves shall be of the resilient wedge gate variety. Butterfly valves shall be placed on water mains 14" or larger in diameter. Valves larger than 12 inches require the valve to be turned with a gear to maintain minimum cover.

### **7.03.02 Water Valve Location**

- A. Water valves shall be installed along the water mains at a maximum spacing of 400 feet and at the intersection of lateral lines. A maximum of 20 service connections between valves shall be maintained except on dead end residential streets where up to 30 service connections between valves are allowed.
- B. Water valves shall be located in clusters at tees and crosses when possible and shall be located so that each leg of the main line system can be isolated separately.
- C. When extending public water mains, a water valve may be required near the end of lines where future extensions are projected.
- D. Water valves shall not be placed within the wheel path of vehicle traffic.
- E. A gravel or paved road surface may be required within the public water utility easement as needed to allow access to valves and other appurtenances.
- F. Valves shall be adjusted to final grade in accordance with City of Auburn **Standard Detail T-05**.

## **7.04 Cross Connection Control**

**See City of Auburn Standard Details W-22 through W25.**

Water Systems shall be designed to protect the City water system from contamination via cross connection control in accordance with Washington State Law (WAC 246-290-490), Auburn City Code (ACC), the City's Cross Connection Control Program manual, and these design standards. Premises isolation shall be provided on service connections and proposed building tenant improvements in accordance with these standards.

#### 7.04.01 Domestic Services

- A. Backflow protection assemblies shall be installed on all new non-single family service connections. Backflow protection assemblies shall be installed on existing non-single family service connections as directed by the City Cross Connection Specialist. The type of backflow protection assembly shall be as determined by the City Cross Connection Specialists.
  - 1) A Reduced Pressure Backflow Assembly (RPBA) shall be installed adjacent to the meter or at an alternate location where the service line enters the building. RPBA assemblies installed at an alternate location, require the approval of the City, shall have no connections between the meter and the assembly, and shall be installed with adequate drainage to accommodate discharges from the RPBA.
  - 2) A Double Check Valve Assembly (DCVA) for domestic service shall be installed adjacent to the meter, unless installed at an alternate location approved by the City Cross Connection Specialists.

#### 7.04.02 Irrigation Services

- A. A backflow prevention assembly shall be installed on all irrigation service connections. The layout of the backflow prevention assembly shall be per City of Auburn **Standard Detail W-06** for single family residential services up to 2 inches and per City of Auburn **Standard Detail W-20** for non-single family residential services. The minimum level of backflow prevention required shall be provided by a Double Check Valve Assembly (DCVA) per City of Auburn **Standard Detail W-24**. A higher degree of protection may be required if deemed necessary by the City Engineer, which may include a Reduced Pressure Backflow Assembly (RPBA) per City of Auburn **Standard Detail W-22**.
- B. The backflow prevention assembly shall be installed adjacent to the meter.

#### 7.04.03 Fire Line Connections

- A. A backflow prevention assembly shall be installed on all fire service connections. The layout of the backflow prevention assembly shall be per City of Auburn **Standard Detail W-09** for single family residential services up to 2-inches and per City of Auburn **Standard Detail W-20** for non-single family residential services. The minimum level of backflow prevention required shall be provided by a Double Check Valve Assembly (DCVA) per City of Auburn **Standard Detail W-24**. A higher degree of protection may be required if deemed necessary by the City, which may include a Reduced Pressure Backflow Assembly (RPBA) per City of Auburn **Standard Detail W-22**.
- B. The backflow prevention assembly shall be located in the building riser room.

#### 7.04.04 General

- A. A DCVA shall be installed to provide adequate access for inspection, testing and maintenance.
- B. A DCVA located outside the building shall be installed in a vault, as described on City of Auburn **Standard Detail W-24**.



- C. A DCVA located inside the building shall be installed per City of Auburn **Standard Detail W-25**.
- D. An RPBA shall be installed in an above ground enclosure or at alternate location with no connections between the meter and assembly (**see** City of Auburn **Standard Detail W-23**). An RPBA is required for all services utilizing chemicals.
- E. Prior to installation, 2 sets of backflow prevention assembly plans, including the connection point to the City main, shall be submitted for review and approval by the City.
- F. Only assemblies listed on the current list of Backflow Prevention Assemblies Approved for Installation in Washington State shall be allowed. This list is maintained by the State of Washington and is available from the City.
- G. When multiple buildings are proposed on a parcel the building backflow prevention devices shall all be located outside the buildings or all be located inside the buildings per City of Auburn Standards.

## **7.05 Pressure Reducing Stations**

A Pressure Reducing Station shall be installed as required between pressure zones to maintain adequate pressure in the water system. Isolation valves are required upstream and downstream of the station. Contact the City Water Utility Engineer for specific requirements, when applicable. Water system design shall be done so as to minimize the number of pressure reducing stations necessary.

## **7.06 Fire Systems**

### **7.06.01 Fire Hydrant Assemblies**

**See** City of Auburn **Standard Details W-07 & W-08**.

Fire Hydrant Assemblies shall meet the following requirements:

- A. Fire hydrant assemblies shall conform to the standard details listed above.
- B. Fire hydrant service lines shall be installed at right angles to 8 inch minimum diameter supply mains.
- C. Fire hydrants shall stand plumb, be set to meet manufacturer's specification for ground bury line, and have a clear, level area around the hydrant with a radius of no less than 60 inches.
- D. Fire hydrants shall be located no closer than 50 feet to the surrounding structures, or at a distance as determined by the Fire Marshal and approved by the City Engineer. Fire hydrants shall be located such that no portion of the fire hydrant is within 5 feet of any portion of a driveway (including throat, apron, and wings).
- E. Fire hydrants shall be provided with two 2½ inch National Standard Thread (NST) hose ports and one 4½ inch NST by 5 inch hose port with a Storz adapter and cap.
- F. The pumper port shall face the street or fire access road and be readily accessible to any fire vehicle for firefighting and pumping operations. There shall be at least 18 inches clear from the face of the pumper port to the edge of pedestrian or traveled ways.

- G. The service line from the supply main to the fire hydrant shall be 6 inches in diameter unless the service line extends over 50 feet in length, in which case the service line shall be 8 inches in diameter.
- H. Fire hydrants shall be installed with a maximum spacing of 600 feet along streets in single-family zones and 300 feet in all other zones.
- I. The maximum distance allowed from any part of a single-family residential structure to the closest fire hydrant is 450 feet.
- J. Buildings, other than single-family residences, located with portions of the building more than 150 feet in vehicular travel (see figure below) from a fire hydrant assembly or with building fire flow over 2500 gpm, shall require on-site fire hydrant assemblies. These hydrants shall be served by a public water main that loops around the building, or complex of buildings, and reconnects back to a distribution supply main.

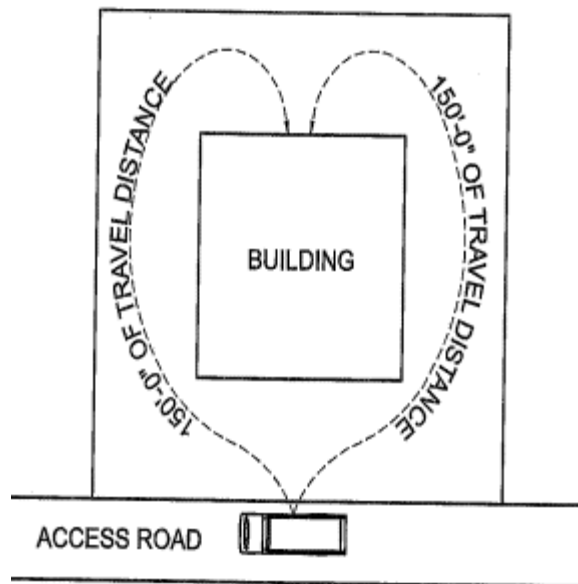

## 7.06.02 Fire Sprinkler Systems

Fire Sprinkler Systems shall meet the following requirements:

- A. Any contractor offering to design, install, test, and/or provide maintenance of fire sprinkler systems in Washington must be licensed with the State Fire Marshal's Office, Licensing Section.
- B. Fire sprinkler systems shall be required in commercial/industrial and multifamily buildings according to the adopted fire code regulations. Sprinkler systems may be required in single-family residences when determined by the City and the Fire Authority.
- C. Fire sprinkler supply lines for commercial buildings, unless designed by a Fire Protection Engineer, shall be a minimum of 8 inches in diameter.
- D. Fire sprinkler supply lines for non-single family buildings shall be connected to a looped water main.

- E. Fire sprinkler supply lines shall be separated from the public water main by a valve located at the point of connection. The fire sprinkler supply line shall be installed with a cut-in tee and shall have a 3 valve cluster unless otherwise approved by the City Engineer.
- F. The design of fire sprinkler supply lines for single-family/duplex shall be in accordance with City of Auburn **Standard Detail No. W-09**.
- G. A Washington State Certified Level "U" contractor shall install underground fire sprinkler supply lines in accordance with WAC 212-80-010. Prior to installation, 3 sets of underground fire sprinkler supply line plans shall be submitted to the City for approval by the Fire Marshal. Both a State Certified Level "U" contractor and a Fire Protection Engineer shall stamp these plans. A letter from a state certified sprinkler system designer stating "FOR DESIGN PURPOSES ONLY" may be attached in lieu of a stamp from the Fire Protection Engineer.
- H. A post indicator valve (PIV) shall be installed on the fire sprinkler supply line between the public water main and the building. PIV's shall be located in such a manner as to be easily visible to Fire Department personnel. A wall-mounted PIV may be installed when the exterior wall of the building is of non-combustible construction. A detail containing this information shall be included with the submitted plans.
- I. Fire Department Connections (FDC's) shall be placed within 50 feet of a fire hydrant or as directed by the Fire Marshal. FDC's must be identified and approved by the Fire Marshal.
- J. New water mains shall be constructed with valves on each side of fire line taps.
- K. Fire sprinkler systems shall have backflow prevention in accordance with **Section 7.04**.
- L. Fire sprinkler service lines shall not be connected to fire hydrant service lines.
- M. Flow-through fire sprinkler systems may be installed for single family residential only. Design shall be according to NFPA 13D. Backflow prevention is not required for flow-through systems.

### **7.06.03 Fire Flows**

New developments, redevelopment of existing sites, or changes in land use are required to meet the minimum City fire flow requirements listed below. The developer shall provide information to the City to define the building specific fire flow requirements. If the building specific fire flow requirements are greater than the minimums listed below, facilities shall be designed to meet the greater requirement.

The minimum fire flow requirements within Auburn Water Service areas are:

- 1) Single Family Residential: 1,500 GPM @ 2 Hours
- 2) Industrial/Commercial/Multi-Family: 2,500 GPM @ 3 Hours
- 3) Additional fire flow may be required per ACC 15.36A.

Minimum fire flows outside Auburn Water Service areas shall be determined by the water service provider and the Fire Marshal.

If off-site water system improvements are necessary to meet these requirements, the Developer shall be responsible for said improvements.

#### **7.06.04 Fire Authority and Hydrant Access**

Fire Authority and hydrant access shall meet the following requirements:

- A. Access shall be a minimum of 20 feet wide with a minimum vertical clearance of 13½ feet and capable of supporting 75,000 lbs gross vehicle weight.
- B. For 20 feet wide roadways, turns in the access shall be designed using a minimum inside radius of 28 feet and a minimum outside radius of 48 feet. The City can provide a turning template for any situation beyond this.
- C. Except as noted otherwise in these standards, access that exceeds 150 feet in length from the face of curb or edge of the existing asphalt of the public road and does not return to a public road shall provide a turnaround within 150 feet of the dead-end. If a hammerhead configuration is utilized for the turnaround, it shall be designed per Figure D103.1 and Table D103.4 in Appendix D of the International Fire Code. If a cul-de-sac is utilized for the turnaround, it shall be designed per the City of Auburn Design Standards.
- D. Single family residential driveways greater than 150 feet in length from the face of curb or the edge of the existing asphalt to a location where a single family home has all portions of the building no more than 150 feet, as measured by an unobstructed route around the exterior of the building, shall have an 18 foot wide driveway apron and a minimum 20 foot wide paved surface.

#### **7.07 Public Water Utility Easements**

Public Water Utility Easements are required for the placement, operation, and maintenance of water facilities upon private property.

Public Water Utility Easements shall meet the following requirements:

- A. Public Water Utility Easements shall extend a minimum of 7½ feet to each side of the centerline of the main and all water appurtenances. Easements shall extend a minimum of 7½ feet either side of the vault walls of pressure reducing stations. Additional easement area may be required for facilities constructed in areas of steep terrain or at greater depths.
- B. Public Water Utility Easements shall be provided on the City's standard easement form. Legal description of the easement and the property that the easement encumbers, along with a sketch showing both, shall be stamped and signed by a licensed land surveyor and incorporated into the easement form as exhibits. The legal descriptions and sketch shall be on plain bond paper with margins acceptable to the County of recording.
- C. Public Water Utility Easements shall be reviewed by the City and then recorded in the appropriate County prior to acceptance of the public water main.

# 8 Sanitary Sewer Facilities

## 8.00 Preface

The design of sanitary sewer facilities shall be in conformance with the applicable sections of the State of Washington Department of Ecology's "Criteria for Sewage Works Design" manual (DOE Manual) unless modified herein. These standards are set forth as a minimum requirement for the planning and design of gravity sanitary sewer facilities. Sewage pump stations and special facilities are not included within this design manual due to the complexity of these facilities. When designing pump stations and special facilities, please contact the City of Auburn Engineering Services for specific requirements.

Compliance with these standards does not alleviate the design engineer from using sound professional engineering practices. The design criteria contained herein are the minimum acceptable under standard conditions. Special conditions may require more stringent requirements that will be addressed during the plan review process.

The City's Comprehensive Sanitary Sewer Plan establishes drainage basins and design parameters used to estimate future line capacities. Anyone proposing to extend or modify the City's sanitary sewer system should contact the Public Works Department for information on proposed line sizes and locations. Sanitary sewer improvements shall be constructed by means of a Facility Extension Agreement (FAC) between the developer and the City. The Community Development Department can provide information on this agreement as well as applicable permit and connection fee estimates.

In lieu of constructing a public sewer system, the developer of a single, non-residential lot may construct a private sewer system, in accordance with the standards for public sanitary sewer systems consisting of manholes and sewer mains. The property owner is responsible for maintenance and repair of the private system. This option is only available if the sewer extension would not serve any additional upstream properties.

## 8.01 Sanitary Sewer Mains

### 8.01.01 Sanitary Sewer Main Sizing/Slope

Public sanitary sewer mains shall be designed using the following criteria:

- A. All sanitary sewer mains shall be a minimum of 8 inches in diameter.
- B. All new lines shall be sized as indicated in the City's current Comprehensive Sewer Plan. For lines not specified in the plan, the applicant must design the line with sufficient capacity to convey any future upstream flows (based on current land use designations).
- C. Sanitary sewer mains shall be designed and constructed to provide a minimum cleaning velocity of 2 ft/s when flowing at 80% full. If at final build out the planned contributing area will not achieve this capacity, additional provisions may be required.
- D. The following are the minimum slopes for the corresponding pipe sizes:

Pipe Diameter	Minimum Slope
8 inch	0.50%
10 inch	0.30%
12 inch	0.25%
18 inch	0.15%

### 8.01.02 Sanitary Sewer Main Location

- A. The desired installation depth for sanitary sewer mains is between 6 feet and 15 feet below the finished surface elevation. For mains less than 6 feet deep and over 15 feet deep, additional provisions may be required by the City.
- B. Sanitary sewer mains shall be located in the public right-of-way or within a public sanitary sewer utility easement per **Section 8.07**. Sanitary sewer mains located in the public right-of-way shall meet the requirements of **Section 9.03**.
- C. When the potential exists to serve upstream properties, sanitary sewer mains shall extend through the property being served, through the shared driveway or access tract serving the property(s), or across the entire length of the lot frontage at the depth necessary to serve the upstream properties, as determined by the City.
- D. The placement of new sanitary sewer mains shall be done in a manner that allows such lines to be readily repaired or replaced without impacting other adjacent facilities or structures in the vicinity. Sanitary sewer mains shall be located a minimum horizontal distance of 10 feet from structures and water mains and a minimum horizontal distance of 5 feet from all other underground utilities. The minimum separation distance is measured from the outside wall of each pipe. **(See Figure 8-01)**

**Figure 8-01 Horizontal Pipe Separation**

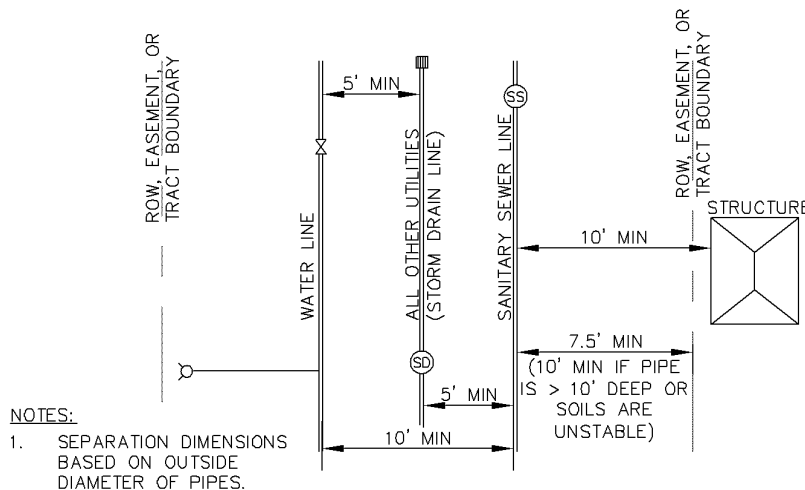

- E. The City Engineer may require the horizontal distance from structures to be increased if soil conditions are poor and/or the sanitary sewer main is deeper

than 10 feet. Minimum pipe clearances shall be measured from the outside wall of the pipe(s).

- F. At crossings between utilities, sanitary sewer mains shall be located a minimum vertical distance of 18 inches below water mains, and a minimum vertical distance of 12 inches from all other underground utilities. The minimum separation distance is measured from the outside wall of each pipe/conduit. **(See Figure 8-02 below).**

**Figure 8-02 Vertical Pipe Separation**

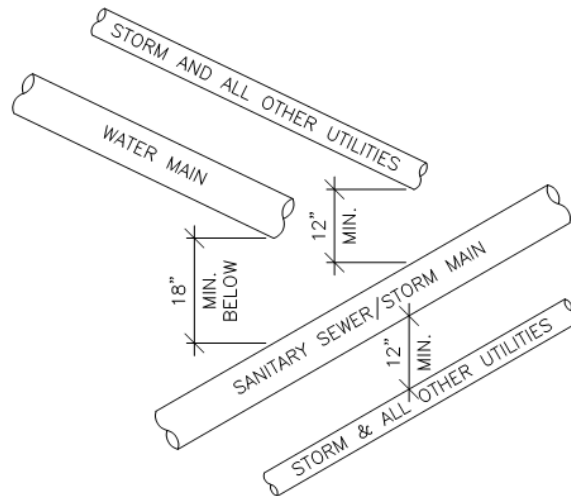

**NOTES:**  
 1. DEVIATIONS FROM THESE SEPARATIONS MUST COMPLY WITH THE DEPARTMENT OF HEALTH MANUAL.  
 2. SEPARATION DIMENSIONS ARE BASED ON OUTSIDE DIAMETER OF PIPES.

**8.01.03 Material Requirements for Sanitary Sewer Systems**

The following is the City’s list of required sanitary sewer pipe materials and depth criteria. Please refer to the City of Auburn’s Construction Standards manual (latest edition) for the most current information on these requirements.

Pipe Type	Minimum Pipe Cover**	Maximum Pipe Depth
Solid Wall Polyvinyl Chloride (PVC) Pipe, SDR-21	18 inches	22 feet
Solid Wall Polyvinyl Chloride (PVC) Pipe, SDR-35 (Requires 13.5 foot lengths).	3 feet	18 feet
Solid Wall Polyvinyl Chloride (PVC) Pipe, C900	12 inches	30 feet*
Ductile Iron Pipe, Special Class 52	6 inches	30 feet*
High Density Polyethylene Sanitary Sewer Pipe (HDPE)***	2 feet	30 feet*

\* Sanitary sewers deeper than 30 feet will require pre-approval of the City.

\*\* Minimum cover is depth of cover excluding cover depth provided by flexible pavements. No portion of any pipe shall be allowed within 6 inches of the bottom of the flexible or concrete pavement.

\*\*\* For use with approval of City Engineer. The design engineer is responsible for specifying a thickness ratio adequate to withstand all loads anticipated for this application.

## 8.02 Sanitary Sewer Manholes

### 8.02.01 Sanitary Sewer Manhole Type and Size

A. Manholes shall be constructed per the following:

Sewer Manhole (48-inch to 60-inch)	WSDOT Standard Plan B-15.20 with an eccentric cone
Sewer Manhole (72-inch to 96-inch)	WSDOT Standard Plan B-15.40 with a flat top instead of riser

B. Shallow sanitary sewer manholes (32"-50" deep) shall conform to City of Auburn **Standard Detail S-06** and may only be used upon approval of the City Engineer.

C. Additional design provisions may be required by the City for sanitary sewer manholes over 20 feet deep..

D. Sanitary sewer manhole diameters shall meet the following requirements based on the manhole depth and the size, number, and configuration of pipes entering:

Manhole Diameter	Number & Diameter of pipes/ Connections Allowed	Depth of Manhole
48" Diameter	1 Pipe, 21" 2 Pipes, 12" – 18" 3 Pipes, 8" – 10"	4' Minimum 12' Maximum
54" Diameter	1 Pipe, 36" 2 Pipes, 21" – 30" 3 Pipes, 12" – 18" 4 Pipes, 8" – 10"	6' Minimum 15' Maximum
60" Diameter	1 Pipe, 42" 2 Pipes, 24" – 36" 3 Pipes, 15" – 21" 4 Pipes, 10" – 12" 5 Pipes, 8"	8' Minimum 20' Maximum
72" Diameter	1 Pipe, 48" – 54" 2 Pipes, 36" – 42" 3 Pipes, 18" – 24" 4 Pipes, 12" – 15" 5 Pipes, 8" – 10"	8' Minimum 25' Maximum



Pipes entering manholes must have a minimum of 8 inches between their penetrations on the inside of the manhole. (See City of Auburn **Standard Detail S-08**)

- E. The angle between inlet pipes and the outlet pipe shall not be less than 90-degrees.
- F. Drop manholes are discouraged. When necessary, drop manholes shall be inside drops conforming to City of Auburn **Standard Detail S-05**.

### **8.02.02 Sanitary Sewer Manhole Locations**

The design of new sanitary sewer conveyance systems shall be done in a manner that minimizes the total number of manholes using the following criteria:

- A. Sanitary sewer manholes shall be installed at a maximum spacing of 400 feet apart along the main.
- B. Sanitary sewer manholes shall be installed at all junctions of two or more sanitary sewer mains.
- C. Sanitary sewer manholes are required whenever connecting to a sanitary sewer main with an 8-inch or larger diameter pipe.
- D. Sanitary sewer manholes shall be installed at all changes in vertical slope, horizontal direction, and/or pipe size.
- E. In cases where a sewer main steeper than 5% must turn 90-degrees through a manhole, install a transition manhole at least 20 feet upstream to reduce the pipe slope to a maximum of 2% and/or to change the angle to 45-degrees.
- F. All public sanitary sewer lines shall end with a manhole. All end of the line sanitary sewer manholes with no side sewers connected directly to them shall conform to City of Auburn **Standard Detail S-07**.
- G. Sanitary sewer manholes are not to be located within the limits of surface water ponding or flow lines associated with stormwater runoff.
- H. Sanitary sewer manhole covers shall be located outside the wheel paths of roadways and driveway approaches.
- I. Sanitary sewer manholes shall not be located within sidewalks, landscape strips trails, or curb and gutters, except as approved by the City Engineer. In cases where manholes are located in walking paths, the manhole cover shall be non-skid, smooth top.
- J. Sanitary sewer cleanouts are not an acceptable alternative for sanitary sewer manholes except they may be used with City approval at the end of a sanitary sewer main, when the future extension of the sanitary sewer main is planned, and the current end point is not a practical location for a manhole. When approved by the City, public cleanouts shall conform to City of Auburn **Standard Detail S-03**.
- K. Sanitary sewer manholes shall not be located on portions of streets or access roads with a slope greater than 8%.
- L. Sanitary sewer manholes shall be subject to the separation requirements from buildings and structures specified in Section 8.02.02.

### 8.02.03 Sanitary Sewer Manhole Parameters

- A. Sanitary sewer manholes shall provide a minimum of 0.10 foot of drop between the inlet pipe and the outlet pipe. Pipes of differing diameters shall be aligned so that the crowns of the pipes match. Where the slope of a pipe entering or exiting a manhole is greater than 5%, the slope shall be continued through the manhole and the invert elevations indicated on the plans.
- B. Manholes are to be channeled from the entering pipe to the outlet pipe, with the sidewalls of the channel extended above the top of the largest connected pipe. See City of Auburn **Standard Detail S-08**. When making a new connection to an existing manhole, the manhole shall be rechanneled to match the new pipe configuration.
- C. Sewer systems shall be designed so that there will be a minimum of 8-inches between pipe penetrations on the inside diameter of each manhole.
- D. Manholes set in gravel areas shall be set at the center of a 6-foot concrete apron flush with the finished grade.
- E. Manholes set in landscaped or unimproved areas shall be set 6 inches to 12 inches higher than the surrounding terrain and provided with a 6-foot diameter concrete apron around the manhole lid.
- F. Sanitary sewer manhole frames and covers shall conform to City of Auburn **Standard Detail S-04**.
- G. Sanitary sewer manholes shall be adjusted to grade per City of Auburn **Standard Detail T-05**. Rubberized adjustment rings may be required in certain circumstances as determined by the City Engineer.

### 8.03 Side Sewers

See City of Auburn Standard Details S-01, S-02 & S-03.

Side sewers are defined as that portion of the sewer system that extends from 2 feet outside of the outer foundation wall of the structure to the public sanitary sewer main. The City maintains the portion of the side sewer located within the right-of-way. The property owner owns and maintains the portion of the side sewer located outside of the public right-of-way. Side sewers located within easements are the property owners' responsibility to maintain.

Side sewers shall meet the following requirements and shall be laid out per **Figure 8-03**:

- A. A separate and independent side sewer from the public main shall be provided for each and every parcel. A separate and independent side sewer from the public main shall be provided for each non-single family building on a parcel.
- B. Side sewers within the public right-of-way and side sewers serving non-single family development shall be a minimum of 6-inches in diameter. The private portion of side sewers serving single family residences may be 4-inches in diameter within the parcel that it serves.
- C. 6-inch diameter side sewers shall be connected to the public sanitary sewer main by the use of a tee (City of Auburn **Standard Detail S-01**) or connected directly to a manhole located along the public main. All side sewer manhole connections shall incorporate a channeled or rechanneled manhole.

- D. Side sewers with a diameter of 8-inches or greater shall be connected to the sanitary sewer system by use of a sanitary sewer manhole which shall be channeled or rechanneled.
- E. When constructing sanitary sewer mains in new developments, side sewer installation shall extend from the connection on the main line to the edge of any utility easements or the public right-of-way, whichever is further.
- F. When installing new sanitary sewer mains or replacing existing mains in developed areas, side sewers shall be installed for all existing occupied structures and any buildable lots. Side sewers shall extend to the property lines and their location shall be clearly marked in conformance with City of Auburn **Standard Detail S-01**.
- G. The maximum length of side sewer from the sanitary sewer main to the building shall not exceed 150 feet except in instances where the side sewer can maintain a 2% slope, a public sewer extension built to shorten the side sewer would not serve any other potential customers, and the applicant agrees to additional requirements, such as but not limited to the installation of additional cleanouts, specified by the City.
- H. Side sewers shall be designed and constructed with a minimum 2% slope from the building to the tee or manhole connection. Where site constraints require that the slope be less than 2%, the City may require larger diameter pipe and/or additional cleanouts.
- I. When an immediate connection to a building is not being made, side sewers shall be designed to provide a minimum depth at the property line of 5 feet below the floor to be served or 6 feet below the street, whichever is deeper. In cases of vacant properties with no anticipated building elevation, the side sewer shall be constructed at a 2% slope from the tee.
- J. Side Sewers shall not have horizontal or vertical bends located within the right-of-way.
- K. Side sewers shall have a minimum cover of 5 feet at the edge of right-of-way.
- L. Side sewers shall be a minimum of 5 feet from potable water service lines.
- M. Side sewer cleanouts shall be installed within 3 feet of the building foundation providing an access point into said line for future maintenance.
- N. Side sewer cleanouts shall be installed at the edge of the property owner's side of the public right-of-way line or utility easement where the ownership of the side sewer changes from private to public.
- O. Sanitary sewer cleanouts shall be installed in side sewers every 100 feet and for each change in direction totaling 90 degrees. **See Figure 8-03**.
- P. If the private portion of the side sewer crosses another private property other than the property being served, a minimum of a 10 foot wide private sewer easement (5 feet on either side of the pipe centerline) must be obtained granting the property owner being served permission to cross said property.
- Q. All side sewers must use push on gasketed joints. Glued joints are not allowed outside the building footprint.

**Figure 8-03 Side Sewer Layout**

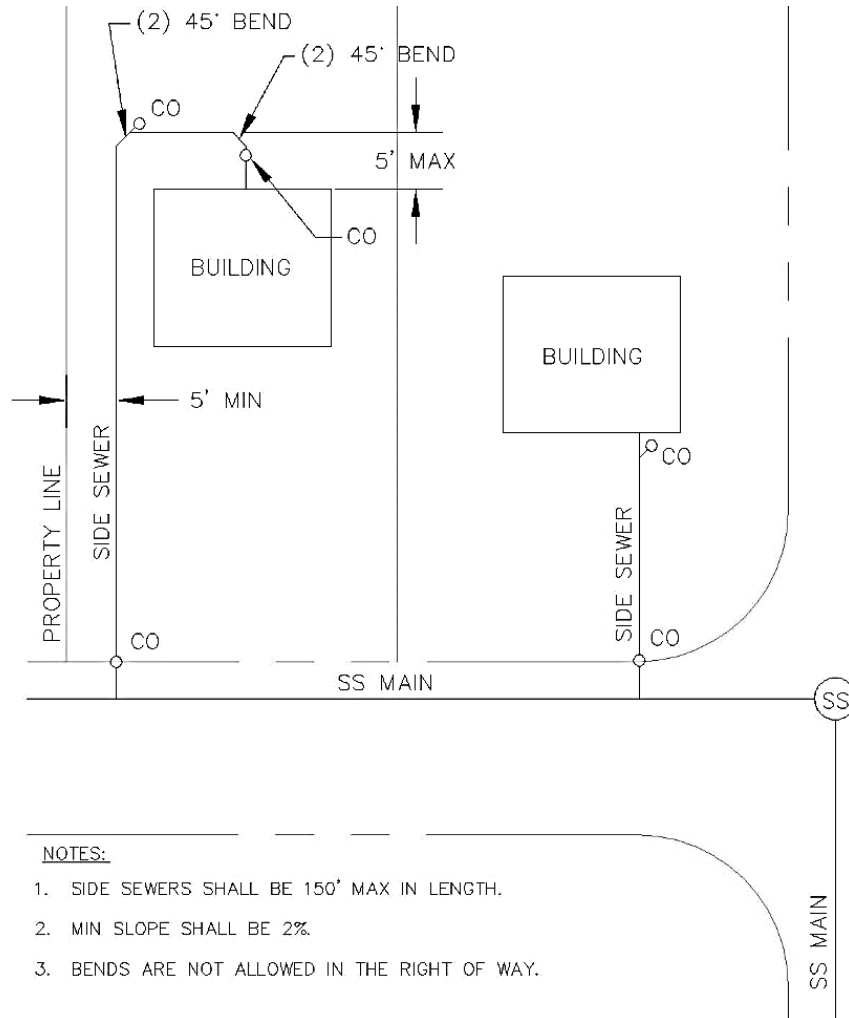

### 8.04 Oil/Water Separators

Prior to discharging into the sanitary sewer system oil separation facilities shall be used in pre-treating drainage flows from fuel islands, trash enclosures, wash pads, and floor drains where (in the sole opinion of the City Engineer) heavy concentrations of oil may occur.

Pads with drains for trash enclosures and wash pads intended for washing the exterior surfaces of vehicles shall drain to a catch basin with a downturned 90-degree elbow prior to discharge to the sanitary sewer. Oil/water separators for other applications shall meet the following design criteria:

- A. A forebay to collect floatable and the larger settleable solids.
- B. A surface accessible inspection T inside the first chamber at the inflow pipe and a sample T at the last chamber at the outflow pipe.
- C. Access to the separator shall be maintained free for inspection at all times.

- D. A maximum of 200 SF of uncovered area open to rainfall may discharge to the separator. Refer to BMP S441 in the SWMM for applications where this may apply.
- E. If a pump mechanism is required to convey the discharge from the site to the sanitary sewer system, the pump must be designed for discharge to a controlled gravity outlet flow into the City system.
- F. The separator shall have a valve on the discharge pipe that can be closed during cleaning and in the event of a spill.
- G. All piping entering and leaving the separator must be 6 inches minimum diameter.
- H. Access points in the top of the separator vault must be provided to allow a minimum twelve-inch diameter access for observation and maintenance to all chambers of the separator.
- I. Access doors shall be galvanized spring-assisted diamond plate with a penta-head bolt-locking latch and recessed lift handle.
- J. Access doors must open a full 180 degrees.

### **8.05 Pressurized Sewer Systems**

Private low pressure sewer systems are allowed only where the existing public system has already been extended to, or is within 200 feet of, the subject property and the elevation differences between the public sewer main and the subject property do not allow for a gravity connection. Extension of a private gravity sewer main onto the property(s) may be required if such extension could make gravity sewer service possible. Sewage from pressurized systems must be discharged into a minimum 6-inch diameter private gravity side sewer prior to connecting to the public portion of the side sewer.

Low pressure sewer systems are not allowed in public right-of-way or public easements.

Low pressure sewer systems shall be owned and maintained by those connecting to it. Systems serving multiple properties shall be within easements or tracts dedicated or owned by all properties connecting to the system.

All other proposed pressurized systems require deviation(s). In addition to the standard deviation considerations required by these standards, deviations requesting pressurized systems must show that extension of the public systems as intended per the Sewer Comprehensive Plan to serve the property(s) and that serving the property(s) with septic system(s) are not feasible. Septic systems may only be considered infeasible if there is no form or scale of a septic system(s) that the County would accept for at least one form of development of the property(s) that would be allowed under the current zoning and land use regulations. Determination that septic system(s) are not feasible require written documentation from the County.

### **8.06 Sanitary Sewer Meters**

The use of sewer meters shall only be allowed if it is determined by the City Engineer that a sewer meter is the appropriate device for the accurate measurement of wastewater being sent into the public sewer system.

## **8.07 Public Sanitary Sewer Utility Easements**

Public Sanitary Sewer Utility Easements are required for the placement, operation, and maintenance of public sanitary sewers located within private property. Public Sanitary Sewer Utility Easements shall meet the following requirements:

- A. Public Sanitary Sewer Utility Easements shall extend a minimum of 7½ feet to each side of the centerline of the sanitary sewer main. Easements shall extend 10 feet to either side when the sanitary sewer main is over 10 feet deep or soil conditions are unstable. The width of the easement is intended to allow adequate space for performing maintenance, repair, and open cut replacements. In unusual circumstances (e.g., steep slopes) the City may require wider easements on a case-by-case basis.
- B. Public Sanitary Sewer Utility Easements shall be provided on the City's standard easement form. Legal description of the easement and the property that the easement encumbers, along with a sketch showing both, shall be stamped and signed by a professional land surveyor and incorporated into the easement form as exhibits. The legal descriptions and sketch shall be on plain bond paper with margins acceptable to the County of recording. The easements may also be described and recorded on a final plat document.
- C. The City will record approved Public Sanitary Sewer Utility Easements in the appropriate County prior to acceptance of the public sanitary sewer facilities, unless part of a final plat document.

# 9 Facilities in the Right of Way

## 9.0 Preface

The design of public and private facilities located within City right-of-way shall be in conformance with these standards. For the purposes of these standards, “facilities” shall include City owned and non-City owned potable water, irrigation water, sanitary sewer, storm drain, gas, communications, electrical, illumination, and any other utility facility and their appurtenances. This chapter also covers non-utility facilities such as building foundation elements, awnings, and private signs.

When a non-City sponsored project requires the relocation of private utilities due to public utility extensions or other City required improvements, the cost of relocation of the private utility shall be borne by the developer.

### 9.01 Franchise/Public Way Agreement Requirement

Private facilities within the City right-of-way require prior approval from the City. Except as allowed otherwise by Auburn City Code, owners of private facilities in the right-of-way shall have a current franchise, public way agreement, or Right-of-Way Use Permit consistent with Title 20 and/or Title 13 and/or Title 12, if applicable, of the Auburn City Code.

### 9.02 Construction Permit Requirement

Any non-City entity intending to construct, repair, or replace any facility in City right-of-way shall contact the City Permit Center and obtain a construction permit. A City permit must be obtained prior to any work within the City right-of-way.

### 9.03 Underground Facilities

Unless otherwise provided in a public way agreement, franchise, or lease, all facilities must be located underground. Exceptions to this standard are as follows:

- Fire Hydrants, Blow-offs, Air/Pressure Relief
- Pipe and cable crossings of rivers and freeways
- High voltage electrical facilities (transmission lines and substations)
- Illumination and signal facilities
- Telephone pedestals
- Aerial cables hung on existing utility poles (with approval of City Engineer)
- Small Wireless Facilities
- Other facilities, that in the opinion of the City Engineer, cannot be reasonably constructed underground.

#### 9.03.01 Design Criteria

The City has established the following minimum requirements to ensure the efficient construction of facilities with the least impact to City transportation and public utility infrastructure:

- A. Public water, sewer, storm, and telecommunications facilities shall be constructed per the Engineering Design and Construction Standards.

- B. Private underground facilities shall be installed with no less than 36 inches of finished cover.
- C. Private underground facilities shall be located a minimum horizontal distance of 5 feet from buildings and public facilities.
- D. When crossing public underground facilities, private underground facilities shall be located a minimum vertical distance of 12 inches from the public utility.
- E. Manholes, valve boxes, power vaults, etc., that are located in the paved area of a street shall be located outside of the wheel paths of vehicles and flush with the pavement surface.
- F. The design of underground facilities shall seek to minimize the number of required structures and redundant pipes/conduits.
- G. Structures located within parking lots, sidewalks, and paths/trails shall also be flush with the surface. In areas where traffic will pass over the structure, load-bearing lids shall be incorporated in the design.
- H. Trenching, backfill, and restoration shall, within paved areas, be per City of Auburn **Standard Details T-01 and T-02**.
- I. Repair of existing cement concrete roadway panels shall be per City of Auburn **Standard Detail T-27**.
- J. Manhole covers, valve covers, vault lids, and other utility appurtenances within pavement restoration areas, including areas of grind and overlay, shall be first lowered beneath the final wear course, paved over, and then raised to final grade per City of Auburn **Standard Detail T-05** and per the Construction Standards Section 7-05.3(1). This requirement may be waived when the total area of the final wear course paving area is less than 100 SF.
- K. The City Engineer may allow required restoration overlays per Standard Details T-02 and T-02A of individual trenches to be deferred where a program or project exists that would complete the restoration/overlay of multiple trenches as a single project or effort. In all cases, permanent repair of the trench is required per **Standard Detail T-01** with the trench construction and backfill and cannot be deferred or delayed.

### **9.03.02 Perpendicular Asphalt Trenching and Restoration Requirements**

- A. Trenching through and within intersections is considered perpendicular trenching.
- B. Perpendicular trench backfill shall be in accordance with City of Auburn **Standard Detail T-01**.
- C. Pavement restoration shall match existing pavement type and thickness with a minimum thickness of 4-inches.
- D. After trenching, the pavement on each side of the trench shall be sawcut and removed (full depth) a minimum of 12 inches from the edges of trench to reveal a clean pavement edge to patch against. This is referred to as the "T-cut"
- E. In the process of perpendicular trenching, if the remaining section of pavement between the edge of T-cut and the edge of the pavement/gutter is less than 4 feet wide, the restoration/overlay will extend to the edge of the road pavement.
- F. In the process of perpendicular trenching, remaining sections of pavement between the edge of T-cut and lane line/lane edges less than 4 feet wide, shall be included in the restoration/overlay area.



- G. When more than 1 perpendicular trench is constructed along a roadway, pavement areas between the limits of the restoration/overlay limits that are less than 10 feet wide are to be added to the required restoration/overlay area.
- H. Perpendicular trenching to roadways may not be allowed on newer roads or streets that have been constructed or overlaid within the last five years.
- I. Perpendicular trenching may not be allowed or may be limited to off-peak hours and/or weekends on principal arterials or where the construction activity will seriously impede large volume traffic patterns. Utility connections that have to be made within the roadway will be allowed after approval from the City.
- J. Jacking/boring alternatives may be required as substitute methods for perpendicular trenching.
- K. The minimum pavement patch width and overlay restoration for perpendicular/transverse trenches shall be per City of Auburn **Standard Detail T-02**.
- L. When multiple trenches are required in close proximity, the asphalt patch shall encompass all the trenches.
- M. The longitudinal edge of the perpendicular asphalt patch shall not lie within the wheel paths of vehicles.
- N. Requirements for curb ramp installation, replacement, and/or upgrade associated with the utility trench work shall be in accordance with **Section 10.06.04**.

### **9.03.03 Longitudinal Trenching in Asphalt Pavement**

- A. Longitudinal trench backfill shall be in accordance with City of Auburn **Standard Detail T-01**.
- B. Pavement restoration shall match existing pavement type and thickness with a minimum thickness of 4-inches.
- C. After trenching, the pavement on each side of the trench shall be sawcut and removed (full depth) a minimum of 12 inches from the edges of trench to reveal a clean pavement edge to patch against. This is referred to as the "T-cut"
- D. In the process of longitudinal trenching, if the remaining section of pavement between the edge of T-cut and the edge of the pavement/gutter is less than 4 feet wide, the restoration/overlay will extend from the trench to the edge of the road pavement.
- E. In the process of longitudinal trenching, remaining sections of pavement between the edge of T-cut and adjacent lane line/lane limits less than 4 feet wide, shall be included in the restoration/overlay area.
- F. Where multiple longitudinal trenches are constructed along a roadway, pavement areas between the limits of the restoration/overlay limits that are less than 5 feet wide are to be added to the required restoration/overlay area.
- G. The longitudinal edges of the asphalt patch shall not lie within the wheel paths of vehicles.
- H. The minimum pavement patch width and overlay restoration for longitudinal trenches shall be per City of Auburn **Standard Detail T-02**.
- I. For streets that have been constructed or overlaid within the last 5 five years, principal arterials, or where open trenching will impede large volume traffic patterns, the City may require that trenching be limited to off peak hours and/or weekends or may require that jacking/boring be researched as an alternative.

- J. Requirements for curb ramp installation, replacement, and/or upgrade associated with the utility trench work shall be in accordance with **Section 10.06.04**.
- K. The City Engineer may allow trench restoration/overlay of individual trenches to be included in a program or project to complete the restoration/overlay of multiple trenches as a single project or effort.

#### **9.03.04 Trenching in Cement Concrete Pavement**

Trenching in concrete pavements shall conform, where applicable, to the previous sections and the following:

- A. The edges of trenches in concrete pavement shall be sawcut prior to excavation to avoid damaging the slab. Concrete slabs 6 inches and over shall be drilled for the installation of dowels. Dowels shall be one and 1¼ inches in diameter, 18 inches long, and spaced 12 inches center to center.
- B. The minimum pavement patch width for concrete trenches shall be 4 feet.
- C. In the process of trenching concrete, if the section of pavement between the trench and the edge of the existing concrete panel is less than 4 feet, the section shall be removed and replaced.
- D. Longitudinal trenches in concrete may be repaved with an asphalt pavement thickness of equivalent strength upon City approval.

#### **9.03.05 Trenching in Other Right-of-Way Surfaces**

Trenching in other right-of-way surfaces, including sidewalks, gravel shoulders, and landscape strips, shall conform, where applicable, to the previous sections and replace the disturbed material in kind or as directed by the City. Utility trench bedding and backfill shall conform to City of Auburn **Standard Detail T-01** and to the Construction Standards.

### **9.04 Aboveground Facilities**

Where underground requirements do not apply, the following parameters will need to be addressed in locating or relocating aboveground utilities:

- A. Clear Zone Requirements: Non-breakaway utility poles and other fixed aboveground utility structures shall meet the clear zone requirements of these design standards (See **Section 10.18**). Respective utility owners shall be responsible for securing easements from adjacent property where clear zone requirements cannot be met within the public right of way.
- B. ADA Requirements: Utility poles and other aboveground utility structures shall not be located within the sidewalk. This requirement may be waived by the City Engineer if pole location in the sidewalk allows a minimum of 48 inches of unobstructed pedestrian travel way and the pole/structure meets clear zone/lateral separation requirements described in Chapter 10.
- C. Utility poles and other aboveground utility structures shall be compatible with driveways, intersections, and all other road features. They shall not interfere with sight distance, road signing, traffic signals, culverts, etc. This may require that existing poles be relocated at the developer's expense.
- D. No utility pole or other aboveground utility structures shall be located in such a way as to pose a hazard to the general public. Utility companies shall locate and replace poles and

other structures with primary consideration given to public safety and roadway functionality.

- E. New overhead power and communications wires and appurtenances shall comply with the vertical clearance requirements established by WAC-468-34-290. Except as may be determined otherwise by the City Engineer to address safety issues, for the purposes of this overhead clearance requirement, replacement of existing facilities and over-lashing of existing cables/wires that do not reduce the existing minimum vertical clearances are not considered to be new. Whether considered to be new or not, plans for overhead power and communications wires and appurtenances must show the existing and proposed vertical clearance of the facilities being installed or modified at each midspan location between poles.
- F. If allowed by the City Engineer, wireless and radio facilities that are not considered Small Wireless Facilities per Chapter 20.14 ACC are subject to the concealment standards cited in Section 9.06.05.

## **9.05 Building and Structure Related Facilities**

Permanent buildings, building shoring systems that would leave any elements in the right-of-way after construction, footings and foundations, and privately owned walls, gates, and fences are not allowed in the public right-of-way.

Facilities such as Awnings, overhangs, and elevated decks/patios/railing (only in the Downtown Urban Center Zone) may be permitted by the City Engineer with special conditions and considered on a case-by-case basis and subject to ACC 12.60.

## **9.06 Small Wireless Facilities**

This section describes design standards for Small Wireless Facilities as set forth in Chapter 20.14 ACC. The purpose of these standards is to provide concealment and safety standards for Small Wireless Facilities in the public right-of-way. Small Wireless Facilities will comply with the following subsections:

### **9.06.01 General Requirements**

1. Small wireless facilities will comply with applicable Federal Communications Commission (FCC), Federal Aviation Administration (FAA), state, and City regulations and standards.
2. A Small Wireless Facility will not be used for mounting signs, billboards or message displays except as approved by the City for the purpose of providing concealment.
3. No lights, other than street lights, are permitted on any pole or antenna unless required by the Federal Communications Commission, the Federal Aviation Administration, or the City.
4. No Small Wireless Facility may be attached to a tree or any other vegetation.
5. Installation of a new pole in the public right of way to serve a Small Wireless Facility will not be allowed whenever an existing pole or other structure in the public right of way can meet technical and network location requirements and the owner of said pole or structure grants permission for the Small Wireless Facility Attachment. If the existing pole or structure does not meet the City's design standards or other requirements, with agreement from its owner, it may be replaced with a pole or structure that meets the design requirements and these standards. In these cases, all attachments must be transferred from the existing pole to the new pole and the existing pole must be completely removed and surface restored.

6. Small Wireless Facilities and all associated facilities, including support poles or structures, will be free from all manufacturer decals and/or logos.
7. Generators are not permitted for Small Wireless Facilities. A battery backup may be permitted through the submittal of a concealment plan and emergency spill response plan.
8. Installation of Small Wireless Facilities is not allowed where it would create a sight distance issue for vehicular or non-motorized traffic, identified in the City of Auburn Engineering Design and Construction Standards.
9. Applications for Small Wireless Facilities will include plans that conform to the plan requirements described in the City of Auburn Design and Construction Standards. Concealment plans will include photos of the proposed site location(s) with overlaid renderings of the proposed Small Wireless Facilities to demonstrate the facility's adherence to concealment standards.
10. Small Wireless Facilities may not share power service connections with City facilities unless specified otherwise in the applicable use agreement for City-owned property.
11. Record construction drawings are required in accordance with the City of Auburn Engineering Design and Construction standards.

#### **9.06.02 Attachments to City Facilities**

1. Attachment, modification, relocation, or replacement of City facilities requires an executed agreement with the City in addition to any applicable franchise or public right-of-way agreements.
2. Attachment to an existing City pole requires calculations sealed by a Professional Engineer that shows the existing pole can support the Small Wireless Facility. Where the existing facility being attached to is a City owned street light, signal pole, sign support structure, or Variable Message Sign (VMS) support structure, calculations must show compliance with the strength and loading parameters stated in the City's Construction Standards. The loading calculations will include consideration of potential future loading with planned or potential future City facility attachments.
3. Small Wireless Facilities are not permitted on City street light poles where they would interfere with street lighting, City banners, flower baskets, holiday lighting, holiday decorations, or other City uses of the pole.
4. Replaced City light poles will be of the same color and similar style as adjacent existing City light poles, unless otherwise approved by the City Engineer. Where a City light pole has been replaced or relocated the davit arm length will be replaced as needed to place the luminaire in-line with the other luminaires along the roadway and in accordance with City design standards.
5. Installation of Small Wireless Facilities on City facilities within secured sites is not allowed. Secure City facilities are those facilities that are enclosed by a fence with locked gate access and typically include water reservoirs, water treatment plants, pump stations, and water wells.
6. Installation of Small Wireless Facilities on traffic signal mast arms is not allowed.

#### **9.06.03 General Pole Requirements**

1. Installation of Small Wireless Facilities on poles intended to break-away from vehicular impact is not allowed.
2. New, replaced, or relocated poles are not allowed within the clear zone (as identified in the City of Auburn Engineering Design and Construction Standards). For the purposes of determining clear zone requirements, poles with Small Wireless Facilities attached are considered utility poles.

3. Small Wireless Facilities will be mounted such that no portion of the facility, including antenna, are higher than 50 feet, or 10% higher than the height of buildings or structures immediately adjacent to the right-of-way, or the Small Wireless Facility attachment does not extend the height of the pole to more than 50 feet or by more than 10 percent, whichever is greater.
4. A pole that is relocated or replaced for the purpose of attaching a Small Wireless Facility is considered an existing structure.

#### **9.06.04 Wiring and Conduit**

1. All wiring must be inspected and accepted by Washington Department of Labor and Industries and associated documentation provided to the City prior to being placed into service.
2. Except on wooden poles and other support structures where internal routing is not feasible, all cables, wires, and fiber must be routed internally in the pole or support structure and must not be visible externally.
3. Wiring, cables, and fiber associated with the Small Wireless Facility will be in their own conduit, interducts, and channels so they are not co-mingled with conduits and cables serving other uses. Electrical wiring will be separated from communications wiring with interduct or separate channels.
4. All interducts, channels, cables, and wiring will be clearly labeled at the pole ends, handholes, junction boxes, and other termination points. Record construction drawings will show and label all cables/wiring, interduct, and channels.

#### **9.06.05 Concealment**

1. Small Wireless Facilities will be screened, concealed, or camouflaged employing the best available technology, such as compatible materials, shrouding, location, color, and other tactics to minimize visibility of the facility.
2. Pole mounted equipment, antenna, conduits, cables, mounting hardware, and other visible components will match the color of the pole they are attached to unless specifically approved by the City.
3. The City Engineer or the City Engineer's designee will consider the cumulative visual effects on the visual character of the surrounding area of Small Wireless Facilities mounted on existing structures and/or located on a given permitted site in evaluating concealment requirements.
4. Where conduit or cables are mounted external to the support structure, the outside cable conduit or cable will be the color of the support structure, and the City may require that the cable be placed in conduit.
5. Full concealment of all conduit, cables, wires, and fiber is required within mounting brackets, shrouds, canisters, or sleeves if attaching to exterior antennas or equipment.

#### **9.06.06 Pole Mounted Antennas and Equipment**

1. Antennas will be located, mounted and designed so that visual and aesthetic impacts upon surrounding land uses and structures are minimized, and so that they blend into the existing environment.
2. Panel antennas shall not be mounted more than 12 inches from the surface of the utility pole, with the distance measured from inside edge of the antenna to the surface of the pole, unless an additional distance is required by the pole owner. An applicant may install a side-mounted canister antenna, so long as the inside edge of the antenna is no more than 12 inches from the surface of the pole.
3. Pole mounted equipment other than the antenna(s), electric meter, and disconnect switch must be concealed within equipment enclosures. Equipment enclosures will be installed flush to the pole and not extend more than 24 inches from the face of the pole.

4. All attachments to a pole that are projecting, or any equipment or appurtenance mounted on the ground, will comply with the Engineering Design and Construction Standards, the Americans with Disabilities Act (“ADA”) standards and will not obstruct an existing or planned sidewalk or walkway.
5. All proposed projecting attachments to the pole will provide a minimum vertical clearance of 12 feet over sidewalks, 16 feet over driveways, and 20 feet over roadways.

#### **9.06.07 Non-Pole Mounted Equipment**

1. Non-pole mounted equipment facilities will be placed underground if doing so is technically feasible and would not defeat the purpose of the facility.
2. Above ground equipment facilities that are not pole mounted will be screened from any street and adjacent property with fencing, landscaping, shrouding, topography, or a combination of these methods,
3. Above ground equipment facilities that are not pole mounted will be treated with graffiti resistant paint or material.

#### **9.06.08 Strand Mounted Small Wireless Facilities**

1. Each strand mounted Small Wireless Facility will not exceed three cubic feet in volume.
2. The strand mounted Small Wireless Facility will be placed as close as possible to the nearest utility pole, but no more than five feet from the pole unless a greater distance is technically necessary or required by the pole owner for safety clearance.
3. No strand mounted Small Wireless Facility will be located in or above the portion of the roadway open to vehicular or non-motorized traffic.
4. Strand mounted small wireless facilities must be installed to cause the least visual impact and with the minimum excess exterior cabling or wires (other than the original strand) necessary to meet the technological needs of the facility.

# 10 Streets

## Preface

The intent of this chapter is to encourage the uniform development of an integrated and accessible public street system that will support present and future multimodal transportation. Through the implementation of these standards, streets are built as transportation facilities as well as public space, contributing positively to the character of an area. These standards help create an efficient multimodal transportation system with minimal environmental impact to the community.

The design of Streets within the City of Auburn shall conform to the standards provided herein. The latest editions of the American Association of State Highway and Transportation Officials (AASHTO) and the State of Washington Department of Transportation (WSDOT) standards shall be utilized by the City Engineer when the design standards, standard specifications, or standard drawings are not covered by the scope of the City's standards.

The design criteria used to estimate future street usage are established in the City's Transportation Plan. Anyone proposing to extend or modify the City's street system should contact the City of Auburn for information. Developers needing to construct street improvements shall enter into a Public Facility Extension Agreement (FAC). The City's Permit Center can provide the information on this agreement as well as applicable permit fee estimates.

It is provided, however, that notwithstanding any provisions to the contrary, streets located within the Downtown Urban Center Zone boundary shown in Figure 1-01 of Section 1.07 of this document, other than that area identified west of the BNSF Railroad right-of-way, shall be subject to the Downtown Sidewalk Design Guidelines. Should any conflict exist between the Downtown Sidewalk Design Guidelines and the design criteria, Chapter 10, of this document, the Downtown Sidewalk Design Guidelines shall control in those portions of the Downtown Urban Center Zone.

All streets shall be designed and constructed to comply with Federal Americans with Disabilities Act (ADA) laws. Additional guidelines and information can be found at WSDOT's ADA web page by clicking on the following hyperlink:

[WSDOT - ADA Guidance](#) .

## 10.00 Required Public Street Improvements

The requirements described in this section are in addition to any requirements determined during the SEPA process to be required to mitigate impacts of the proposed development activity. This section describes the requirements for public improvements triggered by permitted actions as set forth in ACC12.64A.

### 10.00.01 Half-Street Improvements

A public street frontage that requires public improvements is referred to as a "Half-Street". The Half-Street extents are determined using the fronted street's cross section applicable to the street's roadway classification as defined in the City's current Comprehensive Transportation Plan. The Half-Street may apply to an existing roadway or to a planned roadway which has not yet been built. The Half-Street width is the area from the planned right-of-way limits to the planned roadway centerline and extends along the entire length of the subject property frontage(s) with vehicular or non-motorized access. Half-Streets require dedication of public right-of-way and construction of the following elements: paved roadway, sidewalks, curb/gutter, street landscaping, street lighting system, storm drainage, and conduit for City telecommunications. The City Engineer may require

improvements, upgrades or reconstruction of existing improvements within the Half Street that do not conform to current City standards.

For the purposes of evaluating public improvement triggers and where Half-Street improvements are required, gated access that only serves emergency vehicles is not considered vehicular or non-motorized access.

When Half-Street construction is required on unpaved streets or unimproved areas, a minimum of 24 feet of pavement will be required. In these cases, the street will be designed to provide drainage for the constructed portion of the street and to allow for extension of the storm drainage system to the undeveloped portion of the street with future construction. The unfinished side of the Half-Street shall be finished with temporary curbing, shoulders, clear zones, guardrail, slope treatments, and drainage accommodations to assure proper drainage, bank stability, and traffic safety.

If a Half-Street does not connect at both ends to other streets, construction of a permanent or temporary cul-de-sac will be required.

Where Half-Streets are connected to existing streets, transition tapers are required in accordance with AASHTO where edges of pavement do not match.

All required utilities located within the portion of the street being built, shall be installed during construction. Half-Street construction may also require the upgrading of existing utilities if said upgrading was necessary for the proposed development.

When Half-Streets connect to an intersection, the nearest corner of the intersection on the side being improved shall be designed and constructed for the full build-out of the street. The intersection design and construction shall include adequate improvements to insure safe use by pedestrians, bicycles, and vehicles. For half-street improvements required in alleys, the following applies for all development types: Pave the alley to a width of 20 feet along the frontage of the property. If adequate right-of-way does not exist to provide the required 20 feet of pavement adjacent to the property, the appropriate dedication of right-of-way shall be required. Such dedication shall be equally apportioned from both sides of the alley, when feasible, as determined by the City Engineer, and the resultant right-of-way width paved. In addition, for half-street improvements required in alleys for any non-single family development the following applies: Pave the alley between the development and the connection of the alley to the public street at a minimum width of 20 feet or to the width of the existing right-of-way, whichever is less.

### **10.00.02 Additional Improvements**

Additional public improvements besides the Half-Street improvements may be required as determined by the City Engineer to be necessary to mitigate the impacts of the development activity that may include the following improvements, not necessarily located on the property frontage:

- additional street lighting
- additional storm drainage systems
- traffic control and other safety systems including, but not limited to, roadway channelization, signage, non-motorized safety, and traffic calming
- dedication of public right-of-way on public street frontages without vehicular or non-motorized access

### **10.01 Street Classification and Street Layout**

An efficient transportation system seeks to spread vehicle movements over a series of planned streets. The goal of the system is to encourage connectivity while preventing unacceptably high traffic volumes on any one street. Ample alternatives should exist to accommodate access for emergency vehicles. For these reasons the City will continue to plan a series of arterials and collectors designed to national standards to provide efficient service to the community. Ample alternatives should also exist to



accommodate non-motorized transportation on arterials, collectors and local roads within and between subdivisions.

All streets in the City of Auburn have been classified using the Federal Functional Classification system. A map showing the City's street classifications is shown in the Comprehensive Transportation Plan.

New streets and/or new street systems, other than local residential streets serving residential neighborhoods, shall be configured in conformance with the City's comprehensive plan guidelines and policies. Where the comprehensive plan lacks clear guidance to address a particular situation, the City may require traffic studies and other supporting analysis to help define the configuration and nature of the planned street system.

The following section contains descriptions of the street classifications used in the City. **Table 10-1 (included at the end of Chapter 10)** contains information relating to each streets design requirements for widths, radii, typical speed limits, and other information. This section also contains typical cross-sections for each street classification. These cross-sections contain information on street layouts and widths of various street elements. Roadway pavement sections shall conform to **Section 10.01** of these design standards. Streets and street networks will be configured to deter speeding. Traffic calming measures may also be required to deter speeding.

Projected trip generation shall be calculated based on the current edition of the Institute of Transportation Engineers (ITE) Trip Generation Manual.

Streets shall not be linked to a new street if the connection is likely to result in traffic volumes that will exceed acceptable volumes for the road's classification. These volumes are defined in **Table 10-1** of these standards. Consideration may also be given to the character and nature of the neighborhoods proposed to be connected.

### **10.01.01 Arterials**

Arterials are the highest level of City Street classification. They fall under the following two categories: Principal Arterial and Minor Arterial.

#### **Principal Arterial**

**See Figure 10-01 below.**

Principal Arterials are designed to move traffic between locations within the region and to access the freeways. Design emphasis is placed on providing movement of inter-city through-traffic rather than intra-city traffic. Direct access to commercial and industrial land uses is permitted, but managed to improve safety and reduce congestion.

**Figure 10-01 Principal Arterial Typical Cross Section (82' ROW)**

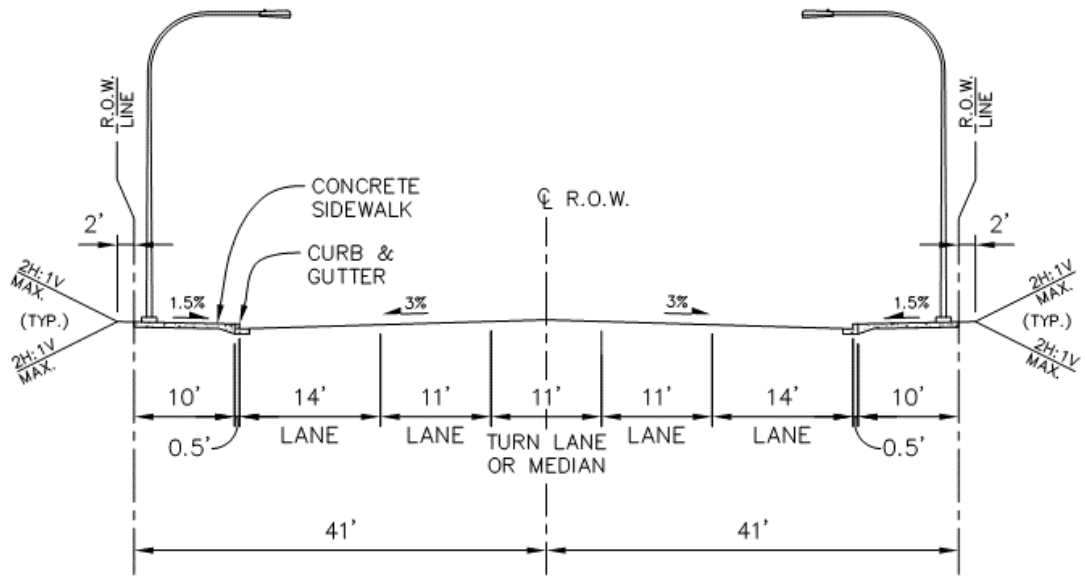

**Figure 10-01 Principal Arterial Typical Cross Section w/Trail (87' ROW)**

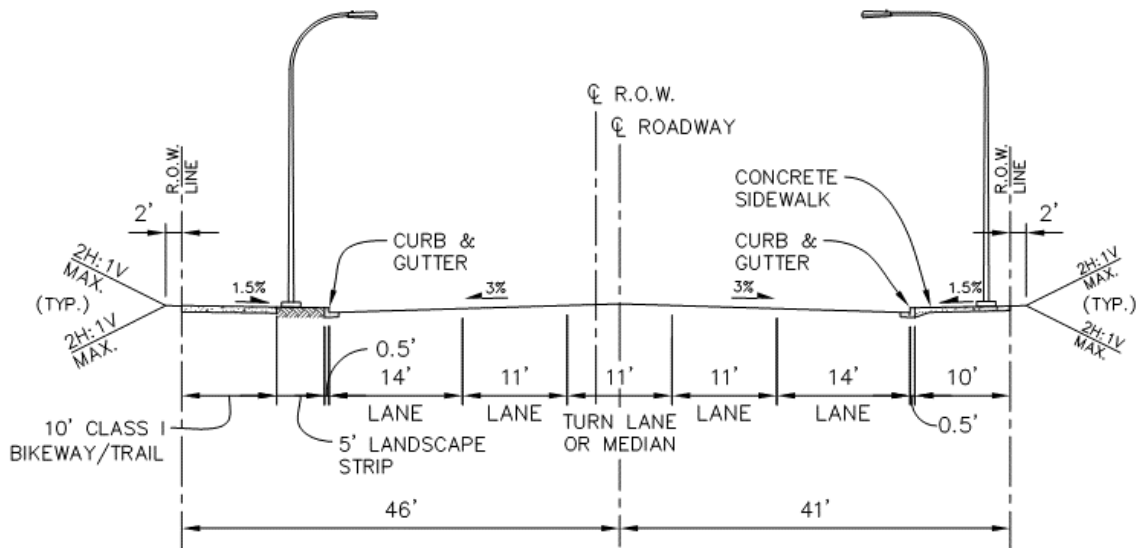

## Minor Arterial

See Figure 10-02 below.

Minor Arterials interconnect with and augment principal arterials and provide service to trips of moderate length at a somewhat lower level of travel mobility than principal arterials. The minor arterial street system includes all arterials not classified as a principal or collector and consists of facilities that place more emphasis on land access than the higher system and offers a lower level of traffic mobility. Minor Arterials may serve secondary traffic generators such as community business centers, athletic fields, neighborhood shopping centers, major parks, multifamily residential areas, medical centers, large church complexes, hospitals, and traffic from neighborhood to neighborhood within the City.

Figure 10-02 Minor Arterial Typical Cross Section

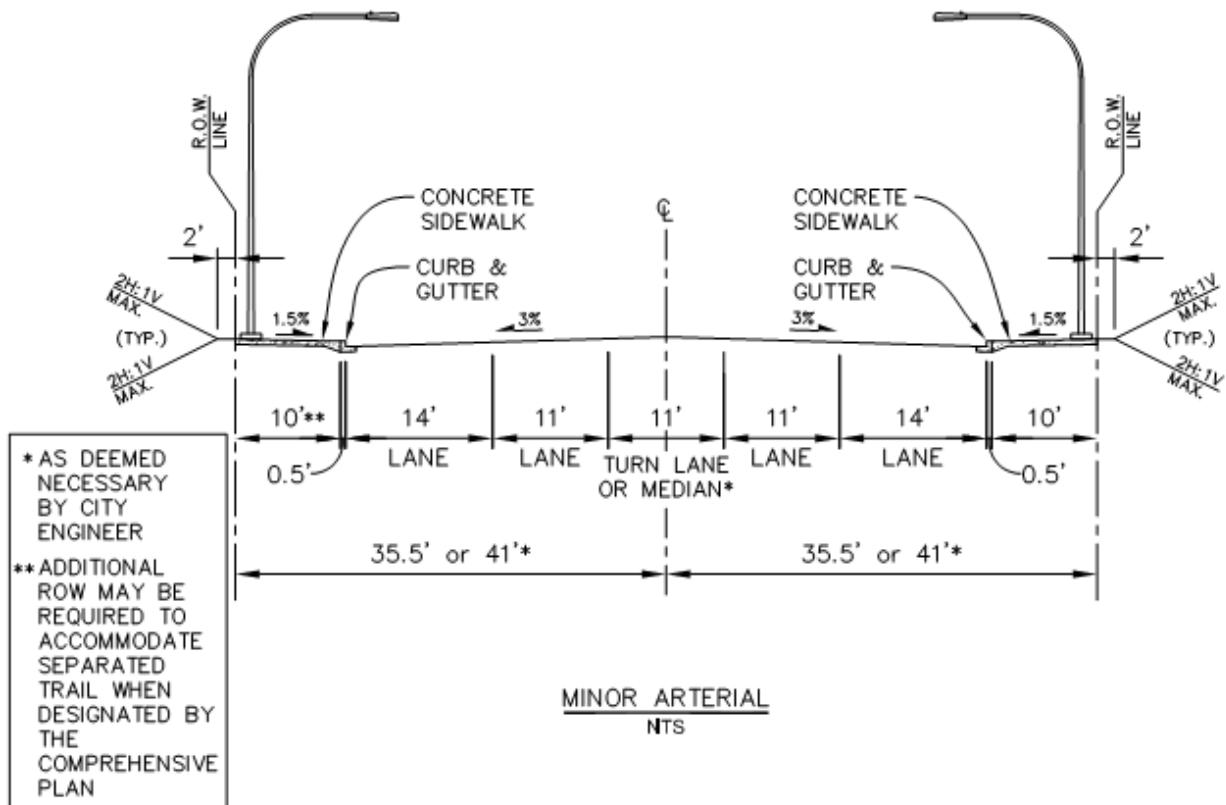

### 10.01.02 Collectors

Collectors are a step below Arterials in the City classification system. They fall under the following three categories: Residential Collector, Non-Residential Collector, and Rustic Collector.

#### Residential Collector

See Figure 10-03 below.

Residential Collectors are used to connect intra-community streets, residential neighborhoods, commercial areas, industrial areas, and community centers to minor and principal arterials.

Residential Collectors are typically constructed to accommodate 2 travel lanes and a two-way left-turn lane or 2 travel lanes and bike lanes.

Figure 10-03 Residential Collector Cross Section

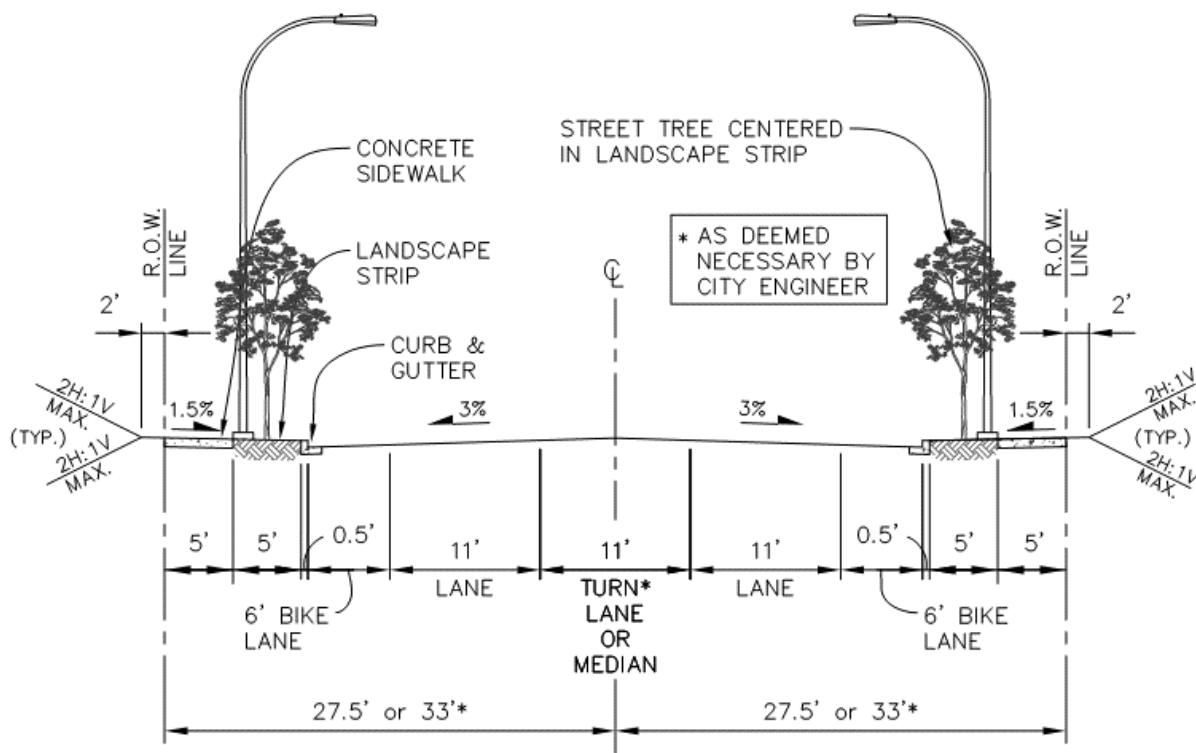

#### Non-Residential Collector

See Figure 10-04 below.

Non-Residential Collectors provide intra-community access connecting non-residential properties with activity centers and recreational facilities. They may serve neighborhood traffic generators such as one store or a small group of stores, elementary schools, churches, clubhouses, small hospitals or clinics, areas of small multifamily developments, as well as other commercial/industrial parcels. Non-Residential Collectors are typically constructed to accommodate 2 lanes and a center two-way left-turn lane.

**Figure 10-04 Non-Residential Collector Cross Section**

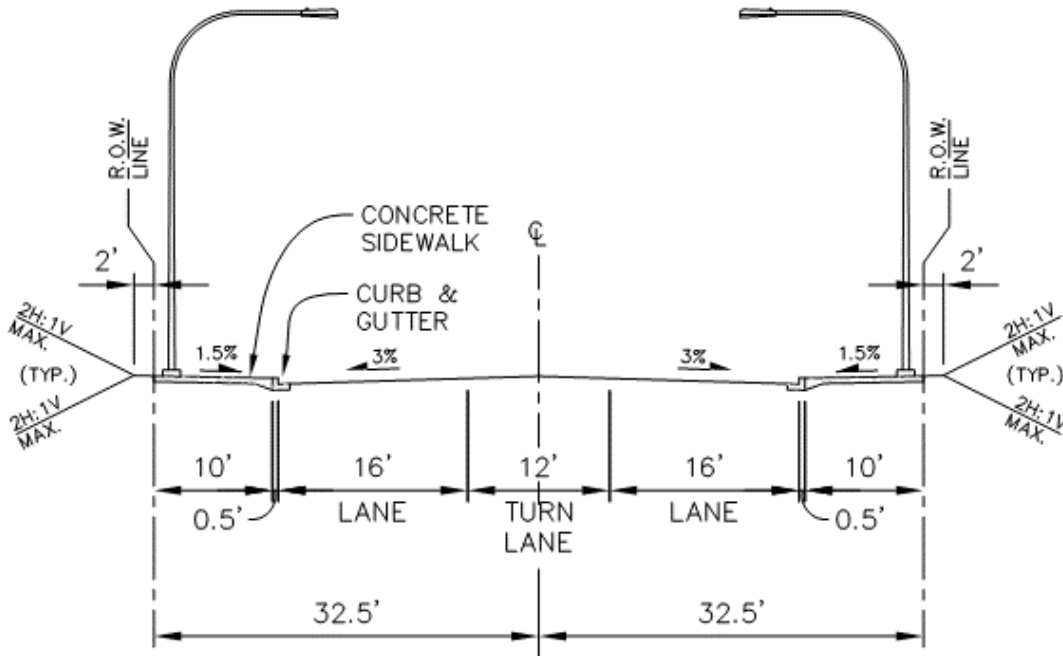

**Rustic Collector**

See Figure 10-05 below.

Rustic Collectors are routes that (regardless of traffic volume) the majority of travel distances are shorter than on arterial routes and residential neighborhoods to activity centers.

Rustic Collectors provide access to all levels of arterials, are typically constructed to accommodate 2 lanes with gravel shoulders on both sides.

**Figure 10-05 Rustic Collector Cross Section**

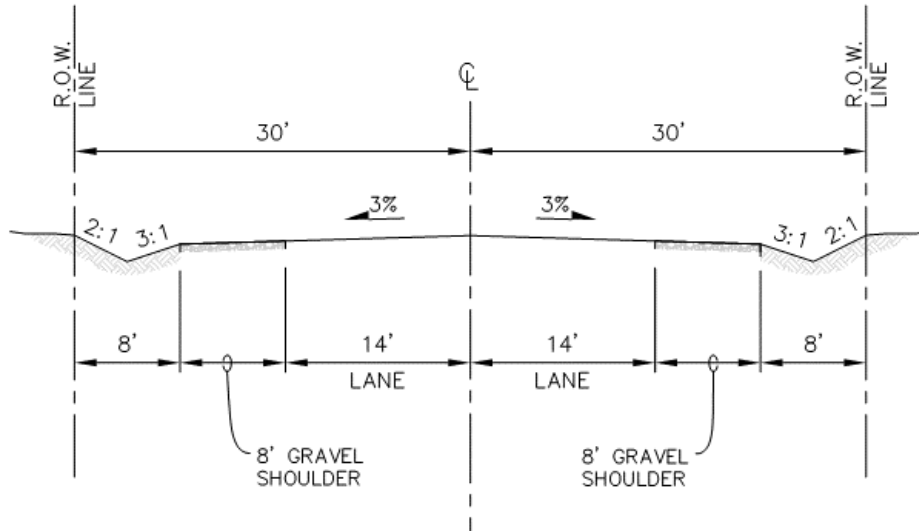

### **10.01.03 Local Streets**

Local Streets are the most common streets in the City. They can be categorized as either Local Residential, Local Non-Residential, or Rustic Residential.

The internal local residential street network for a neighborhood shall be designed to discourage regional through traffic and non-residential traffic from penetrating the neighborhood or adjacent neighborhoods. Local residential streets shall not exceed 1,300 feet in length between intersections.

Residential neighborhoods shall be planned in a manner that limits the number of local street accesses to arterials and collectors to be the minimum number of accesses required to limit the design ADT on existing and planned local residential streets in the neighborhood to the design ADT listed in Table 10-1. Additionally, neighborhoods with over 30 dwelling units are required to have a second access to provide for emergency vehicles given that if the neighborhood has 100 or less dwelling units, the second access to provide for emergency vehicles must be gated and restricted to emergency vehicles only. Non-motorized access may also be provided at the emergency vehicle access. Residential development shall provide for additional non-motorized access to adjacent neighborhoods, roadways, parks, and schools to maintain connectivity.

#### **Local Residential**

**See Figures 10-06, 10-06A, and 10-06B below.**

Local Residential streets provide access to abutting residential parcels. They offer the lowest level of mobility among all street classifications. The street is designed to conduct traffic between dwelling units and higher order streets. As the lowest order street in the hierarchy, the access street usually carries no through traffic and includes short streets, cul-de-sacs, and courts. Service to through traffic movement is discouraged and the street usually contains no transit bus routes.

**Figure 10-06 Local Residential Cross Section**

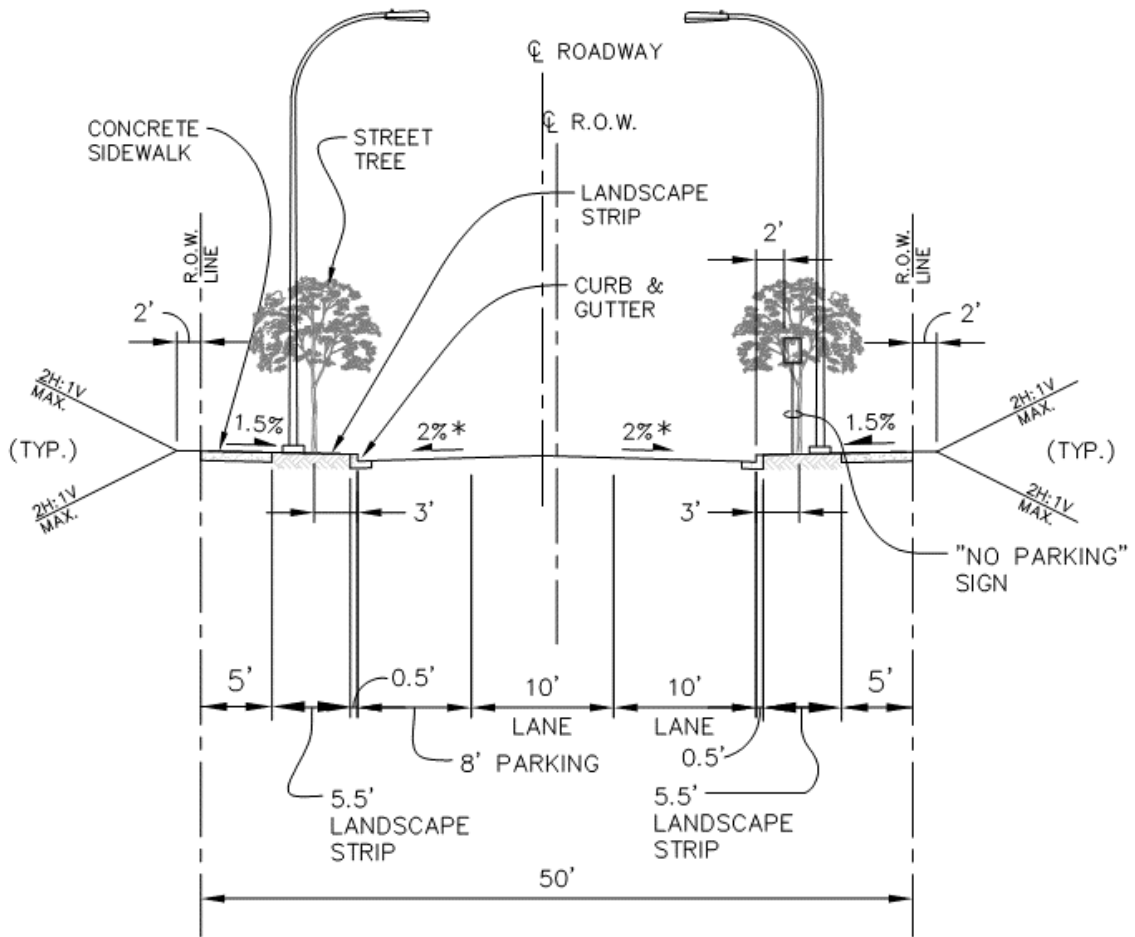
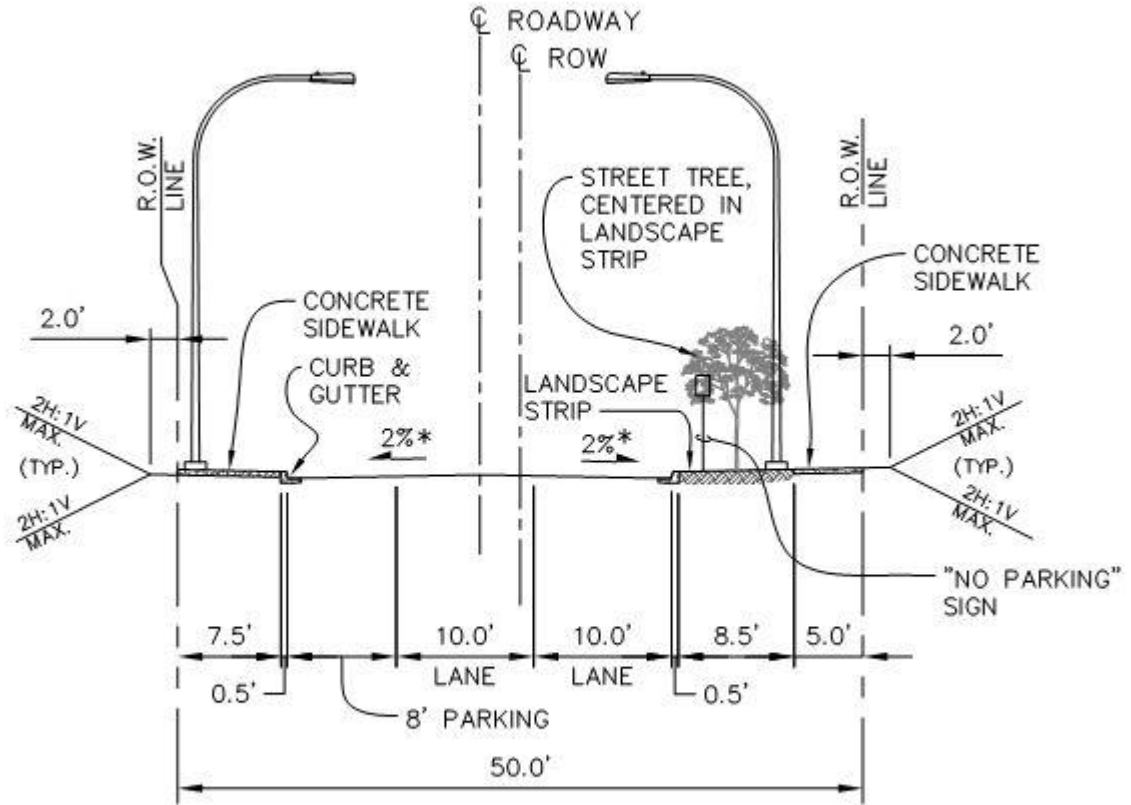

Figure 10-06A Local Residential Cross Section – Alternate



\* CROSS SLOPE MAY BE REDUCED TO 1% FOR PERVIOUS/PERMEABLE PAVEMENT.



Figure 10-06B Local Residential Cross Section – Alternate w/Bioretention Swale

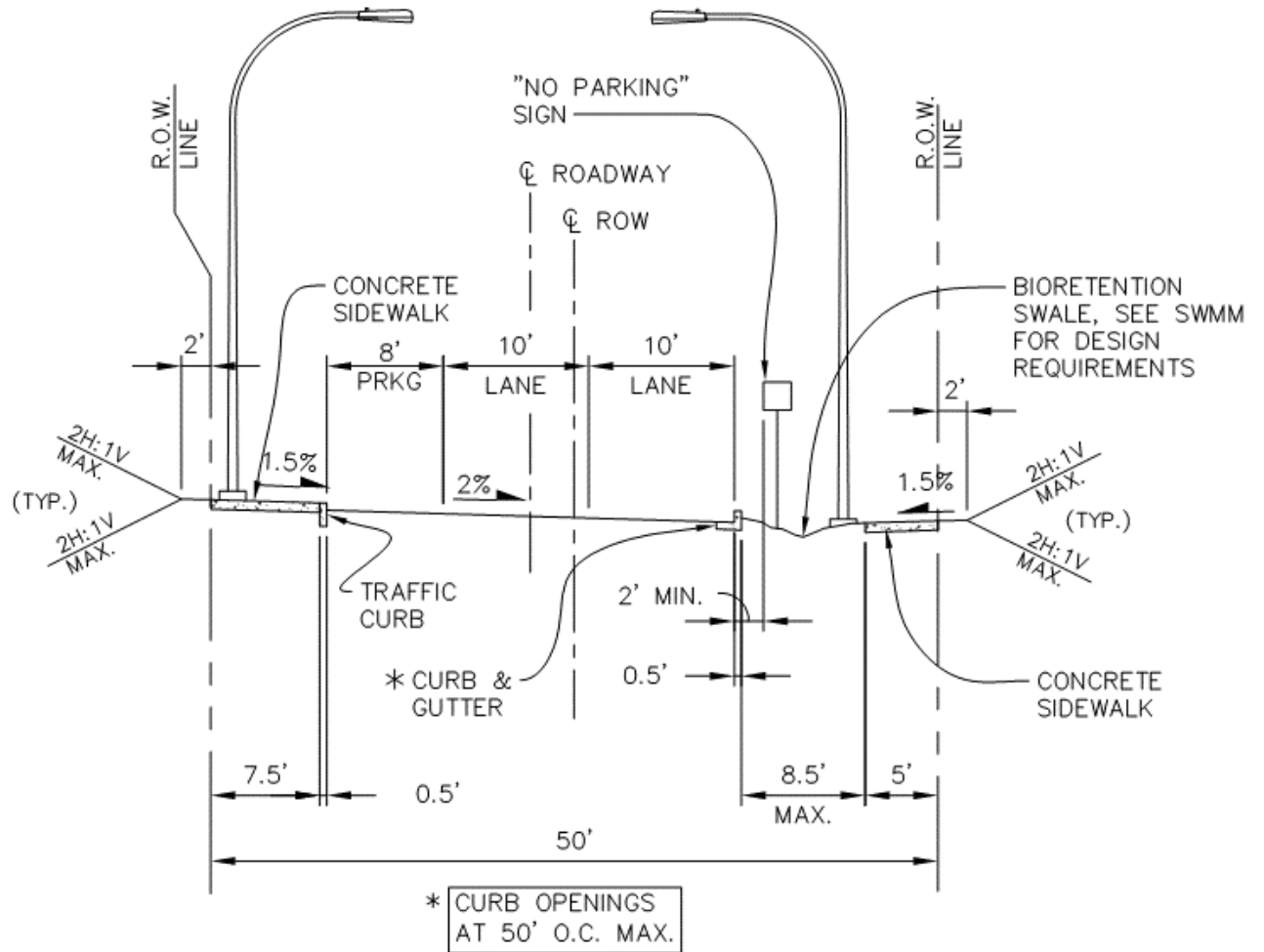

## Local Non-Residential

See Figure 10-07 below.

Local Non-Residential streets provide direct access to higher order classification streets and serve primarily industrial/manufacturing land uses. They offer lower level of mobility and accommodate heavy vehicle traffic. Service to through movement is discouraged.

Figure 10-07 Local Non-Residential Cross Section

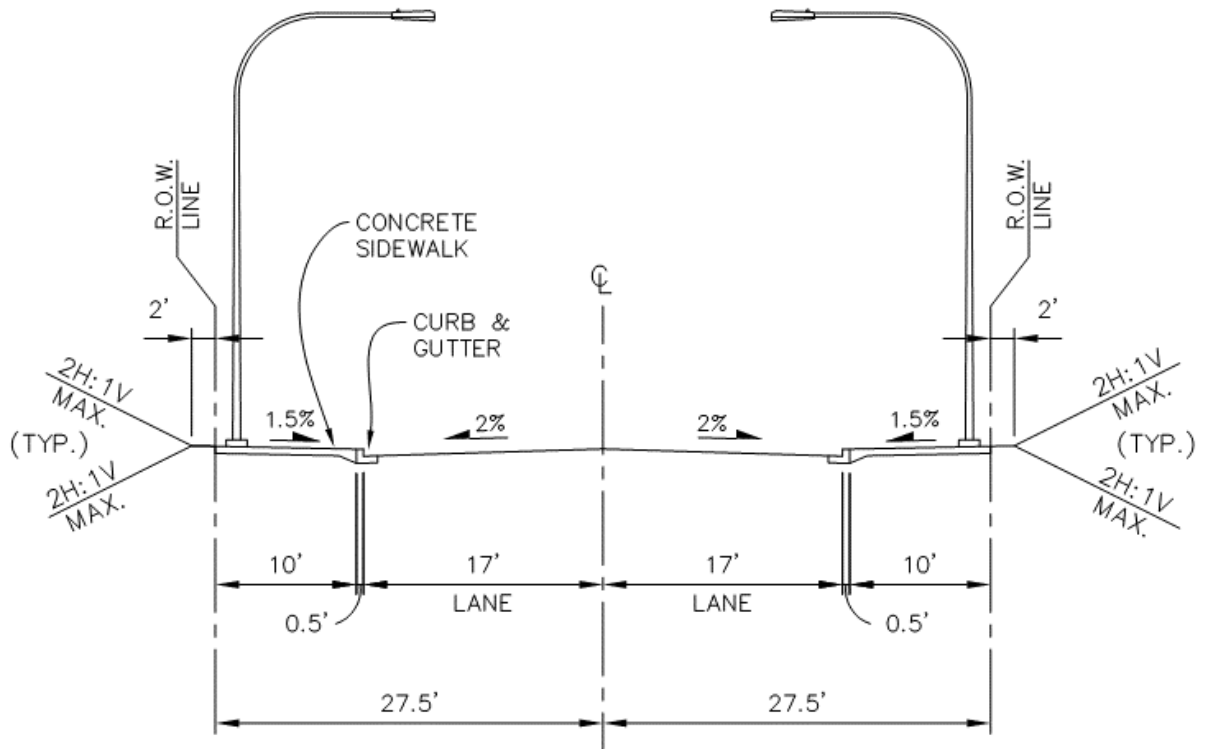

## Rustic Residential

See Figure 10-08 below.

The Rustic Residential streets primarily provide access to the adjacent land and distribute traffic to and from the principal or minor arterials and local access streets. The travel distance is relatively shorter as compared to Rustic Collectors.

Figure 10-08 Rustic Residential Cross Section

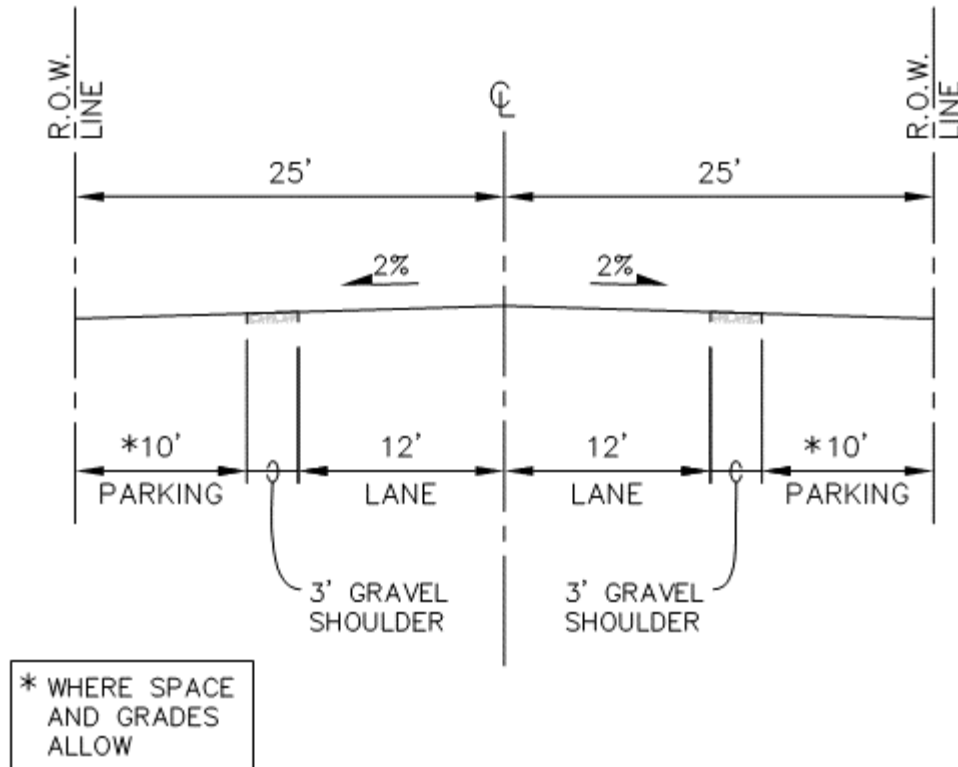

### 10.01.04 Alleys

Alleys provide vehicular access to abutting properties and are not intended for general traffic circulation. Dead-end alleys are generally unacceptable; however, where dead-end alleys are determined suitable by the City Engineer, for short term or temporary applications, they shall be provided with adequate turnaround facilities at the dead-end. All new alleys shall be private.

Alleys shall incorporate the design criteria used in designing local streets with the following exceptions:

- A. Design speed is 15 mph.
- B. All new alleys shall have a minimum width of 20 feet of asphalt pavement.
- C. The pavement section for alleys located in non-single family zones shall be consistent with a local non-residential street standard.
- D. Curb and gutter, sidewalk, lighting, and landscaping are not required along alleys.

- E. Alleys may be paved with either a crown at centerline with asphalt wedge curbs on both sides to control drainage or be sloped to one side with an asphalt wedge curb on one side to control drainage. When necessary, storm drainage conveyance systems shall be installed along the alley to address storm drainage runoff from the paved surface.
- F. Alleys shall connect to City streets via a commercial driveway apron. Alleys serving alley loaded lots shall include provisions for unimpeded vehicular circulation along the alley, and provisions for adequate sight distances along both the alley at driveways and at intersections with public streets.

#### **10.01.05 Private Access Roads on Access Tracts or Easements (Shared Driveways)**

**See City of Auburn Standard Detail T-31.**

Access roads provided on access tracts or easements, also known as shared driveways, provide access for up to 6 residential units on panhandle/flag lots and rear lots that do not have direct access to public street frontage. They will be private roads that shall be maintained by the property owners who use them to access their property.

All access roads shall meet the following general standards:

1. Access roads shall be limited to 600 feet in length. See Note A below.
2. Minimum widths of access/tract easements shall be 22 feet for residential serving 2 or less units, 26.5 feet for residential serving 3 or more units, 35 feet for commercial, and 41 feet for industrial. See Note A below.
3. Minimum pavement width for vehicle egress/ingress shall be 20 feet for residential, 24 feet wide for commercial, and 30 feet for industrial and shall be identified as a fire lane with pavement markings or signage.
4. Edges of access roads without curb/gutter and sidewalk will have an asphalt wedge curb per **City of Auburn Standard Detail T-41**, along the edge(s) to which the roadway drains, if any. See Note A below.
5. Access roads with any existing or anticipated future public utilities shall meet the geometric design standards for local residential streets. See Note A below.
6. Access roads without any existing or anticipated future public utilities shall meet the geometric design standards for local streets except that vertical grades may be increased up to 12% given that all other geometric design and driveway criteria are met including the requirement that a 5% landing be provided for the driveway.
7. Access roads that serve 2 or less residential units do not require sidewalk along the access road. Access roads serving 3 or more residential units require sidewalk, curb and gutter along one side of the access road. Access roads serving commercial or industrial properties require sidewalk, curb and gutter along both sides of the access road. The minimum sidewalk width shall be 5 feet (not including curb) and shall be separated from the vehicular egress/ingress with curb and gutter. Where sidewalks are required and the residential units are along only one side of the access road, the sidewalk shall be placed on the side of the road with the residential units. See Note A below.
8. Driveway connections to the access tract shall be configured such that vehicles backing out of the driveways complete their maneuvers within the access tract without entering another property.

9. The connection of an access road to the public street shall be by a commercial driveway apron. The connection of individual lots to the access road shall be by either a residential or commercial driveway apron commensurate with the use of the property.
10. Access roads shall be signed as private drives inclusive of all addresses being served off the access road.
11. Access roads exceeding 150 feet in length shall include a turnaround at the end of the road. If a hammerhead configuration is utilized for the turnaround, it shall be designed per Figure D103.1 in Appendix D of the International Fire Code. If a cul-de-sac is utilized for the turnaround, it shall be designed per the City of Auburn Design Standards. The turnaround area must be paved and lie entirely within the access tract or easement. See Note B below.
12. Access roads shall include storm drainage facilities in accordance with Chapter 6 of these standards.

Note A: May be excluded for Development of a single family residence on an existing platted lot that only has access to an existing shared driveway where inclusion of the requirement would require additional property rights beyond the applicant's control, modification of existing building and structures, impacts to critical areas, or other reason as deemed acceptable by the City Engineer.

Note B: Requirement may be waived by City Fire Official for Development of a single family residence on an existing platted lot that only has access to an existing shared driveway where inclusion of the requirement would require additional property rights beyond the applicant's control, modification of existing building and structures, impacts to critical areas, or other reason as deemed acceptable by the City Engineer.

### **10.01.06 Private Street**

The City Engineer will determine on a case-by-case basis whether or not a private street will be allowed. Besides the Private Access Roads described in these standards, private streets are generally discouraged and will only be considered for approval by the City Engineer under the following circumstances:

- The street does not provide a current or future planned connection between public roadways.
- The street does not provide current or future access to properties other than those whom would own the private street.
- The street would not result in land locking present or planned parcels.
- The street would only serve a single planned apartment, townhome, condominium, industrial, or commercial development project.
- The street would directly connect to a public street.

Private streets will be in conformance with the street standards that most closely reflects their intended use, with a minimum of 36 feet of pavement width or 28 feet of pavement width with a marked fire lane on one side.

Private streets shall be located within permanently established tracts or easements. A capable, legally responsible owner or homeowners' association shall be established to maintain private streets. A plat or short plat with private streets requires an executed recorded Private Street Maintenance Agreement and a Storm Water Easement and Maintenance Agreement that obligate the future property owners to maintain the infrastructure indefinitely.

### **10.01.07 Cul-de-sacs**

Where possible, streets shall be planned, designed and constructed to connect to future developments. All permanent dead-end streets shall end in a cul-de-sac. Permanent dead-end streets will only be allowed where a through street to connect adjacent properties and/or other streets is not needed or not possible. Streets that are expected to be extended in the future are considered temporary dead-end streets. Temporary dead-end streets that exceed 150 feet in length shall have a temporary cul-de-sac. Dead-end streets shall not be more than 800 feet in length as measured from the center of the nearest intersection to the center of the cul-de-sac. Dead end streets ending in permanent cul-de-sacs shall serve a maximum of 30 dwelling units. When applicable, non-motorized paths shall be provided at the end of the street to shorten walking distances to an adjacent arterial or public facilities including, but not limited to, schools or parks. Existing stub-end streets that are greater than 800 feet in length shall be linked to other streets whenever the opportunity arises, unless it can be demonstrated that such connections would lead to a substantial rerouting of through traffic onto the street.

Maximum allowable vertical grade/cross-slope on cul-de-sacs is 5%.

#### **Temporary Cul-de-sacs**

Temporary cul-de-sacs may be provided only when there is a plan for extending the street.

Temporary cul-de-sacs shall have a paved surface with a diameter of 65 feet.

A sign shall be posted at the back of the temporary cul-de-sac stating that the road is planned to be extended in the future and to contact the City of Auburn Public Works Department for further information.

#### **Permanent Cul-de-sacs**

Permanent cul-de-sacs shall have a paved surface with a diameter of 75 feet to the face of curb and a 7 foot sidewalk unless otherwise directed by the City.

Permanent cul-de-sacs right-of-way shall have diameter of 90 feet unless otherwise directed by the City.

Street Lights and Fire Hydrants shall be placed in an easement behind the sidewalk.

## **10.02 Street Geometry**

Specific geometric design requirements are listed in **Table 10-1** (included at the end of Chapter 10). For in-depth design information on the geometric design criteria, reference the AASHTO Manual "A Policy on Geometric Design of Highways & Streets," latest adopted edition.

In addition to the standard deviation criteria listed in Section 1-04, deviations from geometric design standards shall consider the classification of the roadway, traffic circulations, traffic congestion, emergency access, adjacent property access, length of geometric deviation, and impact to public utilities.

### **10.02.01 Horizontal Curves**

Horizontal curves shall be designed to provide the minimum radii required for vehicles to safely negotiate a turn without leaving their driving lane and shall in no case violate minimum sight distance requirements. Minimum radii are established by the design speed of the street on which the curve is located.

### **10.02.02 Reverse Curves**

Sections of straight roadway must be designed between curves to avoid quick left-right transitions that could potentially lead to loss of vehicular control. Where reversing curves are superelevated, tangents between curves shall be of sufficient length to accommodate transitions into and out of the superelevated sections.

### **10.02.03 Superelevations**

The process of superelevating a street provides a constant cross slope from one edge of the roadway to the other. This allows vehicles to travel around a turn at a higher speed than would be possible if the road were a normal crown cross section.

### **10.02.04 Vertical Grades**

Deviations to the maximum allowed vertical street grades of arterial and collector roadways shall generally not be granted unless it can be demonstrated that, and the City Engineer determines that, the public benefits significantly outweigh any potential detriments.

Vertical grades may be increased to 10% without deviation for local residential streets where all other geometric design criteria are met.

Deviations will only be considered for up to a 8% maximum grade for arterials and a 10% maximum grade for non-arterials. If approved, deviations for roadway grades above 8% may trigger the additional following design considerations, as determined to be necessary by the City Engineer:

- Increased travel lane widths
- Enhanced Paving Section
- Incorporation of Separated Multi-use trail
- Incorporation of Median Islands
- Enhanced Intersection/Signal Improvements

### **10.02.05 Vertical Curves**

Vertical curves are required where a change in vertical alignment equals or exceeds a 1% algebraic grade difference. Crest vertical curves shall be designed to provide the required minimum stopping sight distance for the streets design speed. Sag vertical curve lengths shall be designed to provide headlight sight distance equal to or greater than the design speed stopping sight distance. All vertical curves must be symmetrical, parabolic, and meet AASHTO standards.

### **10.02.06 Cross Slopes**

City streets shall be crowned in the middle to provide drainage to the gutter line or roadside ditches. The cross slopes created by this crown shall be 2% for local streets and 3% for collectors, arterials, and roads with vertical grades of greater than 6%. The cross slopes of roadways constructed with pervious/permeable pavement may be reduced to 1%. Collectors and arterials shall have steeper cross slopes since the higher speeds associated with these roads require that water drain more quickly from the roadway to avoid hydroplaning.

### **10.02.07 Posted and Design Speed**

For design of new facilities, including design of new facilities connecting to existing facilities, the "Design Speed" shall be 10 mph greater than the Posted Speed for arterials and 5 mph greater than Posted Speed for non-arterials. The "Posted Speed" of any new street segment shall be as designated in Table 10-1 .

### **10.02.08 Right of Way**

The required right-of-way will depend upon the width of the street and other improvements. Excluding cul-de-sacs, the typical requirement is for the right-of-way to extend a minimum of 10 feet behind the curb line on each side of the street. Additional right-of-way may be required for bike/pedestrian trails, retaining walls, or storm facilities, for example. Right-of-way requirements may be variable within a street corridor due to intersections, turn lanes, bus loading zones, and other street features.

Right-of-way shall be conveyed to the City on a recorded plat or by a right-of-way dedication or separate instrument.

The minimum right-of-way requirements for the various street classifications are shown in the roadway cross sections in Section 10.01.

The minimum right-of-way requirements for the various curb radii shall be as designated in **Table 10-1 (included at the end of Chapter 10)**. At intersections with two different street classifications, the highest classification for curb radii shall be used except at intersections with residential streets where the lowest order street shall be used.

### **10.02.09 Sight Distance**

Minimum sight distance requirements are to be determined using the current edition of AASHTO's "A Policy on Geometric Design of Highway Streets"

The minimum sight distance for pedestrian safety shall be as shown in **Figure 10-10** below and determined as follows: The driver of an existing vehicle shall be able to view a one-foot-high object 15 feet away from the edges of the exiting lane or lanes, measured at the back of the sidewalk, when the driver's eye is 14 feet behind the back of the sidewalk.



**Figure 10-10 - Pedestrian Sight Distance**

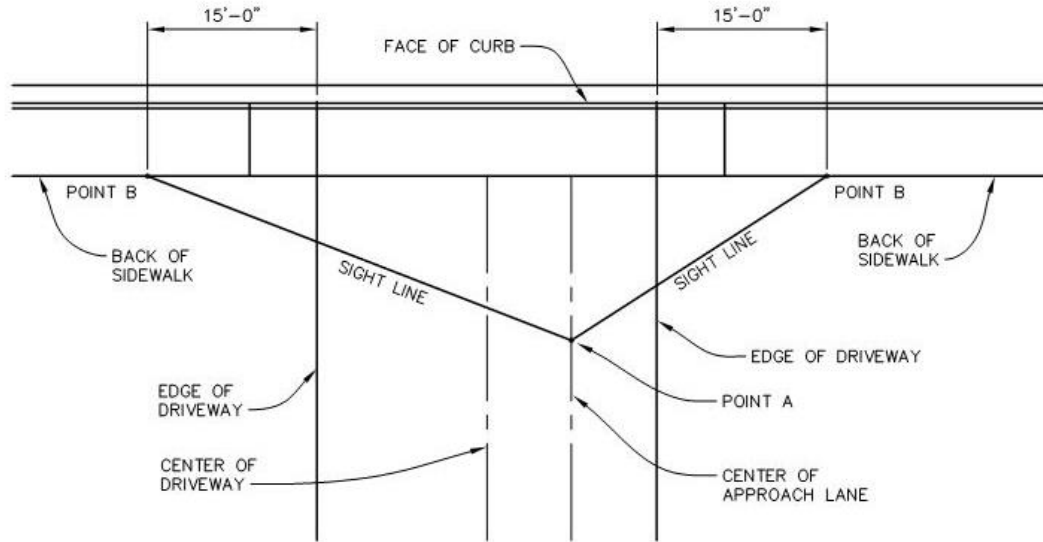

### **10.03 Roadway Width (Travel Way)**

The roadway width or travel way consists of inside through lanes and/or curb lanes, center turn lanes and/or bike lanes (where required), and curb and gutter. Special cases may also require acceleration and deceleration lanes and right and left turn pockets. Total roadway width is measured from the face of curb to the face of curb.

#### **10.03.01 Inside Through Lanes and Curb Lanes**

The street classification and the amount of existing and projected traffic will determine the number of lanes required for a street.

Curb lanes or outside lanes on all streets excluding residential collectors and local and rustic residential streets shall be a minimum of 14 feet wide. Streets will be widened to include inside through lanes based on street classifications and/or projected traffic volumes. The minimum width for inside through lanes shall be 11 feet.

#### **10.03.02 Center Turn Lanes**

Center turn lanes will be required on principal and minor arterials. They may also be required on collectors depending upon the nature of the roadway and the number of left turn movement opportunities along the corridor. Center turn lanes shall be a minimum of 11 feet wide.

#### **10.03.03 Other Lanes**

Acceleration and deceleration lanes may be required for sites located on arterials where heavy volumes and/or heavy truck movements into and out of the site would impact the speed and safety of the arterial.

Left turn and right turn pockets may be required at intersections with large numbers of left and/or right turns. Left turn pockets shall be a minimum of 11 feet wide with right turn pockets a minimum of 14 feet wide.

#### **10.03.04 Road Edge**

All urban roads within the City of Auburn shall be designed using concrete curb and gutter per **WSDOT Standard Plan F-10.12, Traffic Curb & Gutter** at the roadway flowlines/flowpaths. Curbs that are not along flowlines/flowpaths may be constructed as cement concrete traffic curb per **WSDOT Standard Plan F-10.12, Traffic Curb & Gutter**. Rustic roads within the City may be designed with a gravel shoulder (minimum of 3 inches Crushed Surfacing Top Coarse (CSTC) over 8 inches of Gravel Base; eight 8 feet wide for rustic collectors and 3 feet wide for rustic residential and a ditch for drainage. Rustic roads shall also meet AASHTO standards for a clear zone between the edge of pavement and any obstructions. Drainage inlets and grates along curbs shall be constructed per **WSDOT Standard Plan F-10.16**.

The maximum slope of the area between the back of the sidewalk and any cut/fill slope shall be 3%.

#### **10.03.05 On-Street Parking**

On-Street parking requirements shall be as designated in **Table 10-1 (included at the end of Chapter 10)**. For Local Residential streets where parking is allowed on one side only and there are landscape strips present on both sides of the road, the parking shall be placed on the side of the street that can accommodate the most parking. For Local Residential streets where parking is allowed on one side only and there is a landscape strip and/or bioretention swale on only one side of the roadway in accordance with **Figures 10-6A and/or 10-6B**, the parking shall be placed on the opposite side of the street from the landscape strip or bioretention swale.

Parking is not allowed at any of the following locations:

1. Within 20 feet of an uncontrolled intersection measured from the point of tangency on the entering curb radius.
2. Within 30 feet of a stop, yield or signal controlled intersection measured from the point of tangency on the entering curb radius.
3. Within any intersection. For "T" intersections, the no parking limits shall apply to both sides of the through street (top of the "T"). See **Figure 10-09 below**.

**Figure 10-09 - T-Intersection Parking Restrictions**

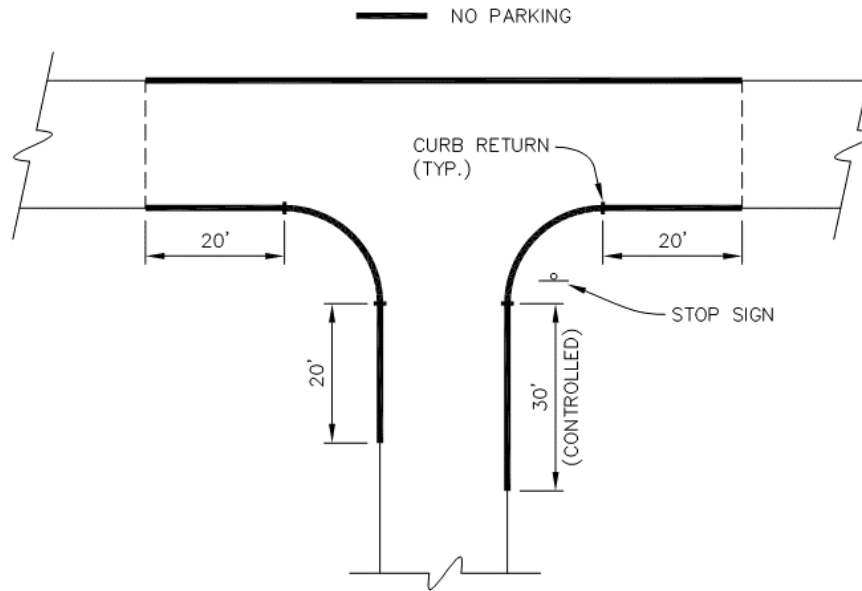

4. In front of or within 15 feet of each side of a fire hydrant.
5. In front of or within 5 feet of each side of a driveway.
6. Where mid-block crosswalks are installed, no parking shall be allowed on either side of the street within 50 feet in advance of the nearest edge of the crosswalk and within 20 feet past the furthest edge of the crosswalk. In no case shall the advance parking restriction for crosswalks be less than the minimum stopping sight distance of the roadway.

Additional parking restriction may be required depending upon roadway geometrics, adjacent land use, and the proximity to bridges and railroads.

## **10.04 Roadway Intersections**

The following sections contain design criteria for street intersections. These criteria are minimum values and may need to be modified according to safety factors, traffic volumes (existing and/or projected), topography, design speed, design vehicle requirements, drainage, and other conditions, both existing and projected.

### **10.04.01 Intersection Spacing**

Roadway intersections shall meet the minimum centerline spacing requirements as shown in **Table 10-3** below.

**Table 10-3 Minimum Intersection Spacing from Centerline to Centerline**

Minimum Intersection Spacing from Centerline to Centerline (ft.)					
PRINCIPAL ARTERIAL	MINOR ARTERIAL	RESIDENTIAL & NON-RESIDENTIAL COLLECTORS	RUSTIC COLLECTOR	LOCAL STREETS	
500 <sup>1</sup>	500 <sup>1</sup>	250	250	125	LOCAL STREETS
1320	1320	500	500	250	RUSTIC COLLECTOR
2640	1320	500	500	250	RESIDENTIAL & NON-RESIDENTIAL COLLECTORS
2640	2640	1320	1320	500 <sup>1</sup>	MINOR ARTERIAL
2640	2640	2640	1320	500 <sup>1</sup>	PRINCIPAL ARTERIAL
Notes:					
1. Local streets shall generally not be allowed to access directly onto arterials.					
2. Refer to <b>section 10.03</b> for intersection sight distance requirements.					
3. Refer to <b>section 10.05</b> for intersection pedestrian accessibility requirements.					

#### 10.04.02 Horizontal Approach Angle

The horizontal approach angle of public street intersections shall be between 85° and 95° at the centerlines of intersecting streets.

#### 10.04.03 Intersection Approach Offsets

Intersections shall be aligned so that opposing single left turn lanes and through lanes are not offset more than 4 feet as measured from the lane centerline approach tangent.

#### 10.04.04 Curb and Right-of-Way Radius

A minimum curb radius is required at intersection corners for vehicles to safely execute a right turn at a reasonable rate of speed without crossing lanes or encroaching onto the adjacent curb. At intersections of differing street classification, the higher classification street curb radius requirements shall be used. The exception to this rule is for local residential streets where the minimum radii listed in **Table 10-1 (included at the end of Chapter 10)** shall be used. The right-of-way radius is the additional radius required to install sidewalks, landscape strips, and other roadway appurtenances. Additional right-of-way may be required near intersections to accommodate auxiliary traffic lanes and equipment for existing or future traffic signals and street lights. These minimum values and listed in **Table 10-1 (included at the end of Chapter 10)**.

#### 10.04.05 Landing Approach

The landing approach is a defined segment of the street before the intersection and is measured back from the point of tangency of the curb radius on each approach to the intersection. The requirements for minimum landing approach length and maximum landing approach grade are listed in **Table 10-1 (included at the end of Chapter 10) Street Crowns**.

Intersections shall be designed to drain away from the higher classification street. Grades shall match at the center of intersections for equal classification streets. At intersections of differing classification streets, the crown shall be carried through the intersection for the higher classification.

## 10.05 Driveways

All driveways, shall be approved by the City Engineer prior to construction. The following sections contain design criteria for driveways. These criteria are minimum values and may need to be modified according to safety factors, traffic volumes (existing and/or projected), topography, design speed, design vehicle requirements, drainage, and other conditions, both existing and projected.

**Driveways shall be sized and spaced per City of Auburn Standard Detail T-04 and as specified herein.**

**Driveway aprons shall be constructed per City of Auburn Standard Detail T-34 or T-35.** Selection of the appropriate driveway apron type requires consideration of existing conditions adjacent to the driveway and grades of the driveway connection behind the apron. Separating the driveway apron from the pedestrian path is the City's preferred approach (City of Auburn **Standard Detail T-34**) and shall be implemented unless existing conditions present constraints that warrant the use of a drop driveway (City of Auburn **Standard Detail T-35**) as accepted by the City.

Work that requires any portion of a driveway apron to be replaced triggers the requirement to upgrade/replace the entire driveway to meet ADA standards.

### 10.05.01 Driveway Classifications

Driveways can be broken into the following classifications:

- A. Residential Driveways – Residential driveways shall be used when serving single family residence(s) that are not connected to the right of way via an access tract, which requires a commercial driveway.
- B. Commercial/Industrial Driveways – Driveways to all properties except single family residential. The three categories of Commercial/Industrial driveways described below will be determined based on the vehicles expected to use the site.
  - 1. **Light Commercial/Industrial** - Used for sites where the average vehicle use will range from passenger vehicles to small size delivery trucks. Examples include mini marts, strip malls, fast-food restaurants, triplexes, and small apartment buildings.
  - 2. **Medium Commercial/Industrial** - Used for sites where the average vehicle use will range from medium to high volumes of passenger vehicles to multiple medium delivery trucks per day and the occasional large tractor/trailer delivery truck. Examples include supermarkets, large outlet stores, shopping malls, large apartment buildings, and busy retail stores located on arterials.
  - 3. **Heavy Commercial/Industrial** - Used for sites where high volumes of medium to large tractor/trailer trucks enter and exit every day. Examples include manufacturing and storage warehouses.

Driveway uses discussed above may be subject to change based on the street classification on which they are located. For example: a site use that may normally fall under the light commercial/industrial classification may be upgraded to a medium

commercial/industrial classification if it is located on a principal or minor arterial to facilitate moving vehicles off the right-of-way in a more efficient manner.

- C. Temporary Driveways – Driveways to property allowed prior to and during construction only.
- D. Emergency Driveways – Driveways required by the fire department to provide an alternative emergency-only access to the property.
- E. Signalized Driveways – For special circumstances when no other option is available, the City may allow signalized access to a public street from a private access. In such situations, dedication to the City of any right-of-way necessary for maintaining and operating the intersection will be required. Additional mitigation measures may be required to ensure safe and efficient access to the public street. The private leg of the intersection within the right-of-way shall be designed to the applicable public street standard as determined by the City.

### 10.05.02 Driveway Locations

A parcel or development project that incorporates multiple adjacent parcels, shall be limited to one driveway access to a City street (including alleys). In addition to the standard deviation criteria listed in Section 1.03, deviation requests for multiple driveways on a parcel or development project shall demonstrate that the multiple driveways do not create a safety concern or impede traffic flow. A deviation is not required for a secondary driveway for emergency vehicle access only that is provided to meet IFC requirements. Secondary driveways provided to meet IFC requirements require a gate with Knox lock.

To address safety or to mitigate impacts of traffic flow, the City may require two or more contiguous non-single family properties to share a single driveway. When a property has frontage on two or more streets (or alleys), the driveway will be located on the lowest classification of street (or alley)

Driveway accesses within the “Functional Intersection Boundary” shall be either prohibited or restricted. **See Table 10-4 and Figure 10-12.**

The functional intersection boundary is the portion of the street leading up to the intersection required to allow vehicle movements and storage. This is the area within which drivers identify the situation, change lanes, come to a stop, and wait before proceeding through the intersection. Driveways shall be either prohibited or restricted within the functional intersection boundary in accordance with **Table 10-4** and **Figure 10-13**. The functional length of an intersection is measured from the point of curvature/point of tangency (PC/PT) of the curb return. Driveway restrictions include prohibiting either all left turn movements, left turns out of, or left turns into the subject driveway.

The City may also impose driveway restrictions at other locations when a safety hazard is identified or to mitigate impacts of traffic flow along a classified street. Such restrictions shall be incorporated into the design of the driveway in conformance with the provisions of **Section 10.05** in a manner that strives to maintain existing access turning movements to other properties in the vicinity.

Redeveloped properties are not guaranteed that their existing driveways will be retained. Redeveloped properties that meet the requirements for half street improvements, have more than one access point, or do not meet current City standards may be required to eliminate, relocate or modify existing driveway access/accesses.

Except for Local Residential Streets the spacing of driveways and their separation from intersections shall meet the minimum "Functional Intersection Boundary" distances of this Chapter.

**Table 10-4 Distance Requirements for Functional Intersection Boundaries**

Posted Speed (mph)	Speed (ft./sec)	Reaction Time (sec)	Decision Distance (ft.) "d <sub>1</sub> "	Lane Change Distance (ft.) "d <sub>2</sub> "*	Braking Distance (ft.) "d <sub>3</sub> "	Storage Length (ft.) "d <sub>4</sub> "	Distance A (Approaching) (ft.)	Distance A (Departing) (ft.)	Distance B (ft.)
25	37	1.0	37	25	60	50	135	80	172
30	44	1.0	44	40	86	50	176	107	220
35	51	1.0	51	60	118	100	278	140	329
40	59	1.0	59	85	154	100	339	179	405
45	66	1.0	66	105	194	100	399	216	465

\* For single lane approaches where a lane change is not possible, "d<sub>2</sub>" should be omitted.

**Figure 10-12 Functional Length Diagram of an Intersection with Right and/or Left-Turn Lane**

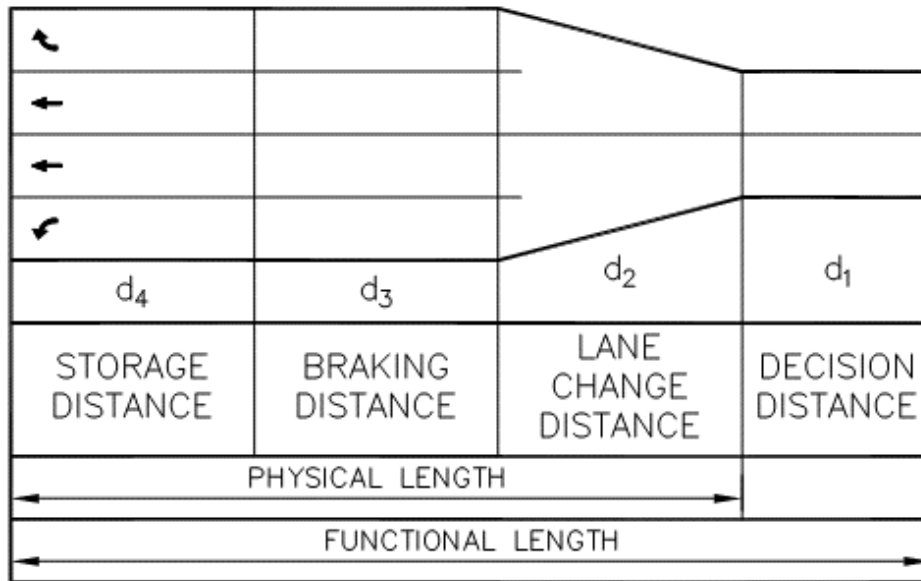

**Figure 10-13 Functional Intersection Boundary Restricted Access Diagram**

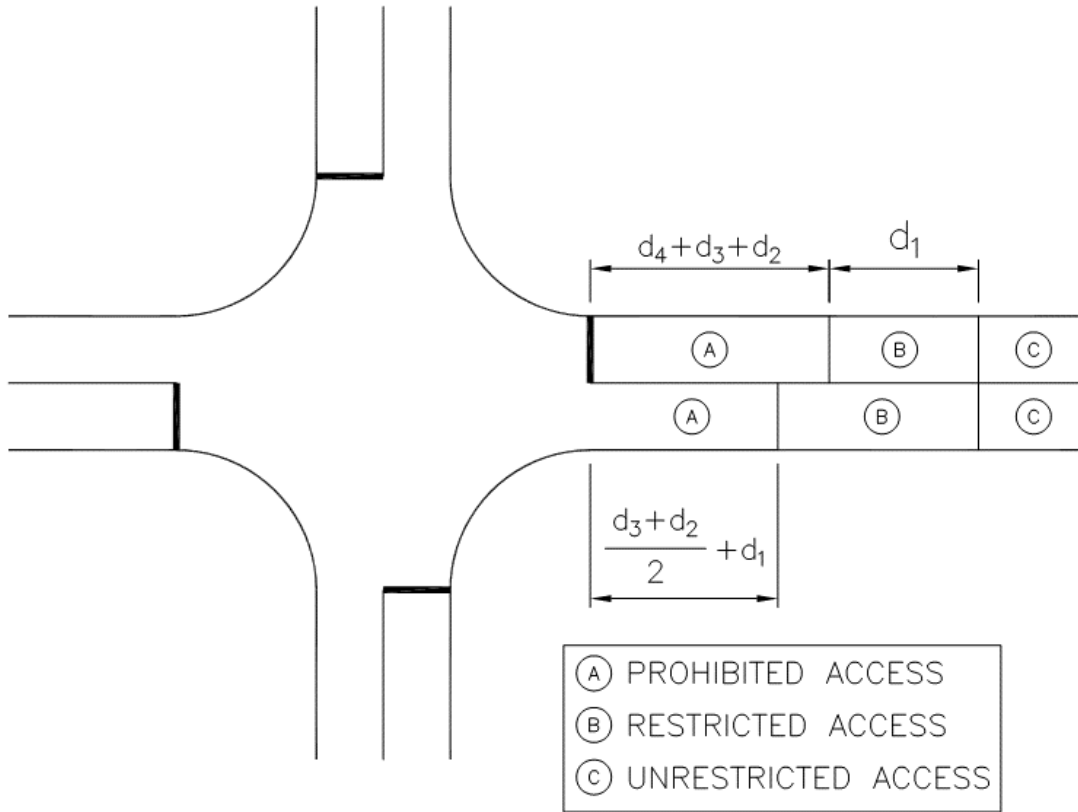

### 10.05.03 Driveway Lay Out

**See City of Auburn Standard Detail T-04.**

Driveways shall be designed in such a manner as to allow for efficient and safe ingress and egress from the City streets. Driveways and on-site parking, other than that for single-family residences on unclassified roads or alleys, shall be designed such that vehicle-backing maneuvers will not occur onto the street. A properly designed driveway shall allow the largest typical vehicle that will use the driveway (i.e. tractor-trailers at large warehouses, delivery trucks at mini marts) to enter and exit the site without encroaching into opposing traffic.

Driveway aprons for adjacent properties shall be separated by a minimum of 10 feet for residential and 50 feet for commercial/industrial. This distance is to be measured from the outside edge of the driveway apron. When this separation is not obtainable, a single driveway centered on the property line may be required.

When designing site layout and driveway access, internal circulation shall be such that on-site traffic will not backup the driveway impeding vehicles in the public street. The City may require sites with internal traffic congestion to design driveways with long throat lengths to provide extra storage to avoid impacting City streets.

Per ACC 18.52.050, commercial and industrial driveways shall have at least a 40 foot throat from the street (not be intersected by parking aisle, parking space, or another access driveway for a minimum distance of 40 feet from the street right-of-way). The City Engineer may require



additional throat distance or may allow less throat distance with the consideration of the following: classification and volumes of street from which access is being taken, total number of parking stalls, design vehicle for parking lot, size of parcel and parking area to which the driveway is providing access, and queueing analysis. If a gate is proposed across a driveway it shall be located a minimum distance of the largest vehicle accessing the site (excluding emergency vehicles), measured from the right-of-way line, unless there is adequate room for parking outside the travel lane(s).

#### **10.05.04 Driveway Alignment (Horizontal and Vertical)**

The angle of driveway throats to the City streets shall not be less than 85 degrees or greater than 95 degrees unless a “pork chop” or other access control device is allowed to be utilized per **Section 10.15**.

The vertical grade behind the driveway shall not exceed 5% for a distance of 12 feet beyond back of sidewalk or right of way line. Driveways shall be designed to preclude vehicles from dragging when entering or exiting the site. Driveways shall meet all sight distance requirements per **Section 10.03**.

#### **10.05.05 Driveway Widths**

**See City of Auburn Standard Detail T-04.**

Driveway widths are measured across the driveway throat and do not include driveway wings/ramps. Residential driveway widths shall be a minimum of 11 feet and a maximum of 18 feet. The allowed width of Commercial and industrial driveways shall be based on the number of lanes used on the driveway and the type of use. Light commercial/industrial driveways shall have one entering lane and up to two exiting lanes with the lane widths restricted to a maximum of 12 feet. Medium commercial/industrial driveways shall have one entering lane and up to two exiting lanes with the lane widths restricted to a maximum of 14 feet. Heavy commercial/industrial driveways shall have one entering lane and one exiting lane with the lane widths restricted to a maximum of 16 feet. Additional driveway apron width will be considered during plan review if turning templates for the largest anticipated vehicle entering/exiting the site are provided.

#### **10.05.06 Restricted Access Driveways**

Restricted Access Driveways are used to restrict turning movements out of or into driveways. Turning restrictions at driveway locations shall be by one or more of the following methods as deemed appropriate by the City.

- A. Median Islands (Per **Section 10.15.01**)
- B. Mountable Curbs (Per **Section 10.15.02**)
- C. Pork Chops (Per **Section 10.15.03**)
- D. Signing (Per **Section 10.15.04**)
- E. Pavement Markings (Per **Section 10.15.05**)
- F. Pedestrian Sight Distance (Per **Section 10.03**)

### **10.06 Sidewalks**

Sidewalk requirements vary by street classification and corridor/area specific standards as determined by the City. Sidewalks are required along both sides of all street classifications except for rustic streets.

See **City of Auburn Standard Details T-13 & T-15**. Pervious sidewalks (where authorized for use by the City Engineer) shall be per City of Auburn **Standard Detail T-14**.

### **10.06.01 Sidewalk Widths**

Sidewalks shall be a minimum of 5 feet in width for all local residential and residential collector streets. Sidewalks shall be a minimum of 10 feet in width for all principal arterials, minor arterials, non-residential collectors, and local non-residential streets. Non-standard widths of sidewalk greater than the standards identified above may be required to maintain continuity on existing corridors. Sidewalk widths in the Downtown Urban Center (DUC) Zone shall be a minimum of 10 feet in width as measured from face of curb to face of building or Right-of-way.

### **10.06.02 Meandering Sidewalks**

The City Engineer may approve meandering sidewalks along a corridor when the sidewalk, landscaping, lighting, signing, right-of-way, and other surface features are integrated into the design of the improvements. Additional right-of-way (or an easement) may be required to accommodate the meander of the sidewalk and other surface features.

### **10.06.03 Accessibility**

All sidewalk cross slopes shall be designed to 1.5% and not exceed 2%. Sidewalk grade shall not exceed the grade of the adjacent street centerline, except at driveways and curb ramps. All sidewalks shall maintain a minimum walking zone of 5 feet in width, free of all obstructions including utilities, signage, street trees, furniture or other elements, permanent or temporary. Sidewalks require a minimum overhead clearance from trees and vegetation of 7-feet when the trees and a minimum overhead clearance of 10-feet from all other objects.

### **10.06.04 Curb Ramps**

See **WSDOT Standard Plans F-40.12, F-40.15 & F-40.16**.

Curb ramps shall be provided at all intersections and pedestrian crossings having vertical curb sections. Every curb ramp shall have at least one receiving ramp. In special conditions, curb ramps shall also be provided to enable passage across curbed radius return access points. All curb ramps shall have detectable warning patterns formed with manufactured truncated domes in accordance with **WSDOT Standard Plan F-45.10**. Truncated dome color shall be yellow except in the downtown urban core area where truncated dome color shall be brick red. Pervious cement concrete ramps and landings shall not be allowed.

For any deficient element that does not meet ADA requirements, designers shall document the deficiency via a Maximum Extent Feasible (MEF) document stamped and signed by a professional engineer. The MEF document will be reviewed for acceptance by the City.

Trenching work and the associated patching and surface restoration that traverse crosswalks/pedestrian pathways (crossings) shall not trigger the requirement to replace curb ramps that do not meet current ADA standards at the crossing, unless, the cumulative width of surface restoration at the crossing for all work associated with the project equals or exceeds half of the crossing width, as measured from curb face or pavement edge at the pedestrian pathway entry into the vehicle travel way to curb face or pavement edge at the pedestrian pathway departure from the vehicle travel way. This distance is measured through medians, islands, and other pedestrian refuge areas. If the cumulative width of all surface restoration at a crossing equals or exceeds half the crossing width, then the curb ramp(s) that intercept the

impacted crosswalk that do not meet current ADA standards must be upgraded/replaced, including signal push-button replacement/relocation where applicable.

Whenever any portion of a curb ramp or intersection corner without a curb ramp is replaced or upgraded for any reason, the entire curb ramp or a new curb ramp is required to meet ADA standards and installation of curb ramp(s) on the receiving end(s) is required if not present.

## **10.07 Bikeways**

The City of Auburn bikeway standards are designed to ensure that bikeways are constructed in a manner that provides a safe and convenient network of interconnected routes for bicycling.

Bikeways are any road, street path or way which in some manner is specifically designated for the exclusive use of bicycles or are to be shared with other transportation modes. Bikeway facilities shall be incorporated into development and transportation projects in accordance with the Future Trail and Bicycle Network plan adopted by the City of Auburn Comprehensive Transportation Plan.

Bikeways shall be designed in accordance with AASHTO's current "Guide for the Development of Bicycle Facilities" the latest adopted edition of FHWA's Manual on Uniform Traffic Control Devices (MUTCD), this section, and applicable City of Auburn standard details.

The City of Auburn's Future Trail and Bicycle Network consists of various classification bikeways. Typically, these bikeways are shared with other transportation modes, although they may be provided exclusively for bicycle use. Bikeways are categorized as follows: Class I Bikeways, Class II Bikeways, Class III Bikeway, and Class IV Bikeways

### **10.07.01 Class I Bikeway**

Class I Bikeways are facilities shared with other non-motorized modes and are physically separated from motorized vehicle roadways. For the purposes of this section, Class I Bikeway design standards are for bicycle facilities that generally parallel a roadway with minimal crossflow by motor vehicles. When required, Class I Bikeways shall be designed for two-way traffic. Class I Bikeways that are part of the City's Future Trails and Bicycle Network shall be public and shall be located within the public right-of-way, tracts or easements.

Class I Bikeways separated from the roadway pavement section (Class I) shall have a minimum pavement section of 2 inch thick CL ½" asphalt concrete pavement over 6 inches of Crushed Surfacing Base Course (CSBC). When the California Bearing Ratio (CBR) of the existing soil is less than 5, an additional 6 inches of gravel base shall be required. When the trail is also utilized as a vehicular service road, the pavement design shall be the Access Road classification on **Table 10-5**. Class I Bikeways shall be separated from the vehicular travel way by a landscape strip/buffer with a minimum 5 foot width.

Where Class I Bikeways are intersected by driveways appropriate signing and pavement markings shall be provided consistent with requirements for midblock crossings.

Class I bikeways shall have a minimum width of 10 feet.

### **10.07.02 Class II Bikeway**

Class II Bikeways, or "Bike Lanes," are incorporated within the street right-of-way. Bike lanes are established on streets in corridors where there is a current of anticipated bicycle demand and where it would be unsafe for bicyclists to ride in travel lanes. Bike lanes shall be provided in accordance with the Future Trail and Bicycle Network plan pursuant to the City of Auburn Comprehensive Transportation Plan. Bike lanes are exclusive one-way bicycle facilities delineated by pavement

markings and signing. Bicycle traffic is carried in the same direction as the adjacent motorized vehicle traffic.

Bike lanes shall have a minimum width of 6 feet as measured from nearest edge of the travel way to face of curb, edge of pavement, or edge of parking lane. Bike lanes shall have the same pavement section as the adjacent roadway.

### **10.07.03 Class III Bikeway**

Class III Bikeways, or "Shared Lane," are facilities shared by bicyclists and motorized vehicles. Class III Bikeways will be utilized, in accordance with the Future Trail and Bicycle Network plan, on existing streets as interim bike corridors until a Class I or Class II facility can be provided. Class III Bikeways may or may not be delineated with shared use pavement markings and signage. Generally, lower-speed/lower-volume streets are adequate for bicycle travel, so additional signing and pavement markings for bicycle use are unnecessary.

Vehicular lanes being utilized as a Class III Bikeway shall have a minimum width of 14 feet as measured from lane line to face of curb, edge of pavement, or edge of parking lane.

### **10.07.04 Class IV Bikeway**

Class IV Bikeways consist of all improved roadways unless otherwise designated as Class I, Class II, or Class III Bikeways.

### **10.07.05 Bikeways at Railroad Crossings**

Railroad-Bikeway grade crossings shall be designed as near perpendicular as possible. If rail crossing is less than 45 degrees, an additional paved shoulder of sufficient width shall be provided to permit the bicyclist to cross the track at a safer angle. Where this is not possible and train speeds are low, compressible flangeway fillers will be required. When not under City control the railroad owner shall be responsible for bicycle crossings.

### **10.07.06 Bikeways at Roundabouts**

Class I Bikeways at roundabouts shall be combined with the adjacent sidewalk, if applicable; to create a single shared use crossing through the roundabout zone.

Class II and Class III Bikeways shall be terminated a minimum of 65 feet in advance of roundabouts using appropriate signing and striping with transitions to the adjacent pedestrian facilities which shall be enhanced through the roundabout zone, consistent with a Class I Bikeway, to accommodate the shared use with bicycles.

### **10.07.07 Bikeways at Signalized Intersections**

Class I Bikeway crossings at signalized intersections shall be combined with the adjacent sidewalk, if applicable, to create a single shared facility utilizing the protected pedestrian crossing at traffic signals.

Class II and Class III Bikeways shall be provided an optional transition to the adjacent pedestrian facilities a minimum of 50 feet in advance of traffic signals using appropriate signing and striping. The adjacent pedestrian facility shall be enhanced to Class I Bikeway standards in advance of the transition point to accommodate the shared use through the intersection.

### **10.07.08 Bikeways at Un-signalized Intersections**

Class I Bikeway crossings at un-signalized intersections shall be combined with the adjacent sidewalk, if applicable, to create a single shared use crossing. Class II Bikeways shall be delineated in accordance with City of Auburn standard details and MUTCD bike lane requirements for intersections.

### **10.07.09 Bikeway Pavement Markings, Signing, and Striping**

**See City of Auburn Standard Detail T-17 and WSDOT Standard Plan M-9.50**

Pavement markings, signing, and striping for bikeways shall be designed in accordance with City of Auburn standard details and Manual of Uniform Traffic Control Devices (MUTCD) requirements.

## **10.08 Pavement Design**

This section of the Standards has been prepared for engineers to use in the design of pavement sections for City streets. The use of the following information will ensure that paved transportation corridors are adequately built or improved in a uniform and consistent manner. Except where indicated otherwise herein, all references to pavement refer to standard pavement sections and not to permeable pavement.

The simplified pavement design approach described in **Section 10.08.01** may be utilized as a simplified approach to determine the required pavement section except for the following streets for which pavement sections must be designed per the current AASHTO design procedure by a Professional Engineer:

- Principal arterials
- Streets where the daily average traffic count is expected to exceed 15,000 vehicles per day
- Streets where truck and bus traffic is expected or encountered, such as freight routes and bus routes
- Freight routes
- Streets where subgrade California Bearing Ratio (CBR) values are less than 3

Freight routes are defined in the “City of Auburn Comprehensive Transportation Plan”. Studies shall be performed along the freight route to determine the vehicle mix and volumes.

### **10.08.01 Simplified Pavement Design**

The simplified pavement design approach may be utilized to determine pavement sections for City streets except for the streets listed in **Section 10-07**. This simplified approach has been developed so that extensive data and computer analysis is not necessary for developing pavement designs for most projects. The approach requires determination of the street’s subgrade conditions and street classification which are then utilized with **Table 10-5** to determine the required pavement design section.

### **Simplified Pavement Design - Street Classification**

The classification of a particular street, (i.e. Residential Collector), can be obtained from the City of Auburn. The classification of a street will be required to determine the volume and mix of vehicles for which it is designed.

In some cases, where a street has yet to be designated a specific classification, street pavement shall be designed based on the anticipated traffic volume. An anticipated daily traffic count can be obtained from the City of Auburn for the street in question or a similar street that functions in the same manner. The City may, however, require the applicant to obtain additional traffic information, as warranted.

### **Simplified Pavement Design - Street Subgrade**

For the purpose of the simplified pavement design, the California Bearing Ratio (CBR) shall be used to classify the type of existing subgrade soils. The scope of this section does not cover existing subgrade with a CBR less than "3". When the CBR is less than "3", the simplified pavement design approach is not allowed.

The subgrade under the proposed street shall have its CBR evaluated by an independent testing laboratory or geotechnical firm. The proposed roadway shall have a minimum of one CBR test for every 1,000 feet of road and/or for every obvious change in subgrade material (minimum of 2 tests per street).

**Table 10-5 Simplified Pavement Section Design Chart**

	Poor Soils (CBR 3-5)	Medium Soils (CBR 6-10)	Good Soils* (CBR 11-20)	Excellent Soils (CBR >20)
Private Streets Alleys Access Roads Rustic Residential	2" CL 1/2" 4" CL 1" 11.5" CSBC Geotextile Fabric	2" CL 1/2" 4" CL 1" 7.5" CSBC	2" CL 1/2" 4" CL 1" 4" CSBC	2" CL 1/2" 3" CL 1" 4" CSBC
Local Streets	2" CL 1/2" 4" CL 1" 11.5" CSBC Geotextile Fabric	2" CL 1/2" 4" CL 1" 7.5" CSBC	2" CL 1/2" 4" CL 1" 4" CSBC	2" CL 1/2" 3" CL 1" 4" CSBC
Residential Collectors Rustic Collectors	3" CL 1/2" 4" CL 1" 14.5" CSBC Geotextile Fabric	3" CL 1/2" 4" CL 1" 9" CSBC	3" CL 1/2" 4" CL 1" 5.5" CSBC	3" CL 1/2" 3.5" CL 1" 4" CSBC
Non-Residential Collectors	3" CL 1/2" 4" CL 1" 14.5" CSBC Geotextile Fabric	3" CL 1/2" 4" CL 1" 9" CSBC	3" CL 1/2" 4" CL 1" 5.5" CSBC	3" CL 1/2" 3.5" CL 1" 4" CSBC
Minor Arterials	3" CL 1/2" 6" CL 1" 18.5" CSBC Geotextile Fabric	3" CL 1/2" 6" CL 1" 11" CSBC	3" CL 1/2" 4" CL 1" 9.5" CSBC	3" CL 1/2" 4" CL 1" 6" CSBC

\*For engineered pavement designs, no pavement design thickness shall be less than the minimum pavement thicknesses identified in this column.

### 10.08.02 AASHTO Pavement Design

Engineered pavement designs shall follow the latest "AASHTO Guide for Design of Pavement Structures" for flexible pavements. For principal arterials no pavement section with an asphalt thickness of less than 7 inches shall be allowed.

For projects where a traffic analysis report was not required, to determine the amount of traffic for which a street is to be designed, contact the City to obtain the most recent street classification and traffic counts. Traffic counts are done assuming there is a 50/50 split in the direction of traffic. 100% of the 50/50 split must be assumed in the design lane, regardless of the number of lanes in each direction. (Additional traffic information may be required.)

The existing traffic levels shall then be inflated to match the projected traffic at the end of the roadways design life (in most cases a twenty-year design life will be used). The annual rate of growth is 1.5% for residential streets and three and 3.5% for commercial/industrial streets and arterials streets. The growth rate may be waived in closed subdivisions with City approval. The minimum pavement section shall be as determined by the pavement design using the AASHTO pavement design approach with a 20-year service life.

The Reliability Level factors used in pavement design shall be in accordance with the following table:

**Table 10-6 Pavement Design – Reliability Factors**

Functional Classification	Required Level of Reliability	
	Urban	Rural
Principal Arterials	95	90
Minor Arterials	90	
Collectors	90	
Local	85	

### 10.08.03 Pavement Design Report

All pavement designs (whether per the AASHTO method or per the simplified approach) shall be documented in a Pavement Design Memorandum stamped and signed by a Professional Engineer and may be included in the project Geotechnical Report where applicable.

The report shall include a narrative of the site conditions, geotechnical boring logs, testing results, calculations, the pavement analysis, and applicable background information for review and approval. The report must contain all calculations regarding the pavement design including, spreadsheets, all variables and assumptions, as well as geotechnical engineering information on the subgrade soils.

### 10.08.04 Permeable Pavements for Roads, Access Tracts, and Shared Driveways

Pervious Cement and Porous Asphalt Concrete Pavement within roads, access tracts, and shared driveways must be designed by a professional engineer. The design shall be documented by a report that includes relevant calculations, data collection, and assumptions. The report must provide evidence that the permeable surfaces are designed to have at least a 30-year service life given the anticipated vehicle counts and classifications. The minimum pavement design section shall be as follows:

- 6-inch thick wearing course of porous asphalt or pervious concrete; over
- 6-inch to 36-inch thick reservoir course (Permeable Ballast per Section 9-03.9(2) of the Construction Standards); over
- Geotextile (Non-Woven, Moderate Survivability per Section 9-33.2(1) of the Construction Standards); over
- Where treatment is required and native subsoils do not meet water quality design criteria per the SWMM: 18-inch to 24-inch runoff treatment layer with specifications per the SWMM.



Permeable pavements shall be designed and constructed per the SWMM and the Construction Standards. Maximum allowed longitudinal slopes for pervious pavements shall be 5%. Longitudinal slopes exceeding 2% shall require check dams or other methods to maximize ponding in the subsurface to allow adequate treatment and infiltration. Underdrains shall not be allowed.

Pervious cement and porous asphalt concrete pavement within the public right-of-way shall not be utilized for storm water management of runoff from areas outside the public right-of-way.

#### **10.08.05 Pavement Surface Restoration and Preservation**

When the total surface restoration area exceeds 1,000 SF feet, pavement core sample(s) are recommended to be collected in the required restoration area to determine the existing pavement thickness. Where the existing pavement to be removed and replaced does not meet current City standards, full depth pavement replacement may be required as directed by the City Engineer.

### **10.09 Street Landscaping**

An area devoted to landscaping is included within the right-of-way of various street classifications. This landscaping is an integral part of the roadway cross-section. It can serve several important functions, including improving pedestrian safety by providing a buffer between traffic and the sidewalk; providing the perception of a narrower travel corridor, thereby slowing traffic; improving air quality; and improving the aesthetic appearance of the street. Street landscaping strips may also be constructed as bioretention swales to provide storm water collection, treatment, and infiltration.

#### **10.09.01 Landscape Strips**

Landscape strips are required for local residential streets and residential collector streets. Landscape strips shall be located between the back of the curb and the sidewalk. Landscape strip requirements:

- The minimum allowed landscape strip width is 5 feet.
- Landscape strips shall be planted with grass or shrubs, vegetation groundcover, and street trees. Shrubs and vegetative groundcover must be low maintenance, minimal debris dropping, and not present a tripping hazard to pedestrians. Landscape strips shall not include gravel, rocks, artificial turf, or other aggregate.
- Roadways, driveways, lighting, fire hydrants, junction boxes, water meters and other appurtenances shall be configured such that no landscape strip has a net landscaped surface area (landscape strip area minus areas occupied by non-landscape features) of less than 50 SF and no portion of a landscaped surface within a landscape strip has a width less than 2 feet. To satisfy these size requirements, landscape strip areas may not be "filled in" with sidewalk, driveway, or other non-landscaped surfaces. Instead, the alternate roadway sections shown in **Figure 10-06A and 10-06B** shall be utilized to ensure that the minimum landscape size requirements are met. These minimum size Requirements shall also apply to bio-retention swales.
- In order to meet the minimum size and width requirements listed above, landscape strips/areas may be omitted from one side of the roadway and widened to 8.5 feet wide on the other side of the roadway. The width of the sidewalk on the side of the omitted landscape strip is required to be increased to 7.5 feet. No parking shall be signed on the side of the widened landscape area. See **Figure 10-06A**. The configuration shall be alternated (the side with the landscape strip/area switched from one side to the other) to support traffic calming and drainage.

- Widened landscape strips/areas may be constructed as bioretention swales as shown in **Figure 10-06B**. Bioretention swales in the public right-of-way shall be designed to collect, treat, and infiltrate runoff from the public right-of-way. If, after runoff from the public right-of-way has been accounted for, additional capacity remains in the bioretention swale, the bioretention swale may be utilized to treat and infiltrate runoff from adjacent private single family residential property(s) with a maintenance agreement between the City and property(s) draining to the swale that requires those property(s) to maintain the swale in perpetuity. The bioretention swale shall be designed and constructed in accordance with the SWMM.
- Landscape strips shall generally be graded towards the curb at approximately 1.5%. Other grades may be allowed where it can be demonstrated to not cause drainage or maintenance issues.

### 10.09.02 Street Trees

Street trees are required for local residential streets, residential collector streets, and streets within the DUC zone. Street trees shall be placed either within the sidewalk in tree pits with tree grates, or in landscape strips. Where landscape strips are constructed as bio-retention swales, street trees shall not be placed in the bio-retention swale and may be required elsewhere depending on the extent of landscape strips constructed as swales. Potential alternative locations include on the private property(s) and/or tract(s) adjacent to bio-retention swale(s).

#### Placement and Spacing

Trees shall be placed so that they do not obstruct the view of any street intersection, driveway, or visibility of any traffic control device or sign. Sight distance triangles shall be used to analyze visibility at street intersections. Trees shall be located in the landscape strip as shown on the typical roadway sections included in these standards. When the roadway section does not include a landscape strip, but street trees are required, trees shall be placed in tree wells with tree grates within the sidewalk per City of Auburn **Standard Detail T-30**.

Nearby features such as street lighting, in-ground utilities, buildings or overhead wires will also affect where trees should be located. Minimum size for street trees shall be a 2-inch caliper, measured 2 feet above the root ball.

Minimum spacing for street trees should be 1-1/2 times the mature diameter of the tree canopy as identified in **Table 10-7A**.

**Planting Next to a Building:** Where a building is placed close to the sidewalk, the mature size of a tree should be considered when selecting species. Trees with a pyramidal, columnar, or oval shaped canopy are preferable; a tree with a round head is generally unsuitable in this situation.

**Overhead Wires:** When trees must be planted directly under or when the mature canopy is within 12 feet of overhead utility lines, species with a mature maximum height of 25 feet must be selected.

**Street Lighting:** Trees need to be located at least half their mature canopy width or 20 feet from street lights, whichever is greater. Planting locations should be coordinated with locations of street lights.

**Street Signage:** Trees shall be planted to avoid blocking the view of street signage.

**Underground Utilities:** Trees shall be planted so as to avoid impacts on underground utilities.

**Clearance:** Trees shall be pruned as they grow to provide at least 8 feet vertical clearance above sidewalks and 14 feet of vertical clearance above roadway surfaces.

## Root Direction Devices

All street trees shall use a root direction device to deflect tree roots downward into the soil. Any tree planted on public or private property within 10 feet or less of a sidewalk or curb shall be planted with a root directional device. These devices are used to eliminate damage to sidewalks as the tree roots extend beyond the original planting pit.

The root barrier shall be placed along two sides of the tree, parallel to the sidewalk and to the curb line. Under specific circumstances, wider strips that contain utilities may also need root barriers to reduce conflicts. Plan submissions shall indicate the location of root barriers and provide a specification sheet on the product to be used.

## Tree Planting Wells and Grates

**See City of Auburn Standard Detail T-06.**

Street trees planted in wells with grated covers are required along streets in the Downtown Urban Corridor Zone (DUC Zone) and as designated by the City Engineer.

## Tree Selection

**Table 10-7A** provides several acceptable species of trees. Many other trees are appropriate and alternative selections may be proposed if desired. Alternative plant choices must be evaluated and approved by the City. Needled evergreens shall not be allowed in landscape strips. Trees with mature heights of over 35 feet shall not be allowed.

Selection of street trees should consider the following:

- **Size** of the landscape strip
- **Canopy shape**

The guidance offered below includes information about which tree canopy shapes work best under different conditions. **Table 10-7A** offers information about tree species and their canopy shapes:

**V-Shaped Trees:** (sometimes also called “vase shaped”) have canopies that are narrow toward the bottom and broad at the top. The American Elm is a classic street tree with this shape. V-shaped trees may have arching branches that form a canopy over both street and sidewalk. They generally do not cause problems with overhead power lines or traffic.

**Pyramidal Trees:** or cone-shaped are typically broad at the base of the canopy and are somewhat pointed at the top. Planted close together, pyramidal trees can screen unwanted views or create vistas. Lower branches sometimes droop with age and may have to be limbed up in later years to provide the needed clearance.

**Round Trees:** These are generally wide spreading trees that need more space than other shapes.

**Oval Trees:** taller than they are wide and cause less interference with traffic.

**Columnar Trees:** useful in locations where there is little available room between the street and buildings, awnings, or other features. Branches of columnar trees tend to grow up rather than out. Many branch lower than other types of trees without causing problems with traffic or pedestrians.

- **Size and type** of leaves
- **Root shape**
- **Site environmental conditions**, such as the amount of sunlight available or moisture in the soil.
- **Aesthetic** qualities desired.

**Table 10-7A Street Trees**

Botanical Name	Common Name	Mature Height (ft.)	Mature Canopy Width (ft.)	Landscape Strips/ Grates	Medians	Canopy Shape	H2O Req	Sun	Remarks
Acer campestre	Queen Elizabeth Maple 'Evelyn'	35	30	x		Oval	Mod	Sun/ part. sun	Hardy tree
Acer ginnala	Amur Maple 'Flame'	20	20	x		Round	Mod	Sun/ part. sun	Good power line tree.
Acer grandidentatum	Rocky Mt Glow Maple 'Schmidt'	25+	15	x	x	Round	Mod	Sun/ part. sun	Requires pruning for clearance
Acer truncatum x A. platanoides	Pacific Sunset Maple 'Warrens Red'	30	25	x	x	Round	Mod	Sun	Good fall colors
Amelanchier x grandiflora	Serviceberry 'Princess Diana'	20	15	x		Upright/ round	Mod	Sun/ part. sun	Small tree, red in fall
Amelanchier x grandiflora	Serviceberry 'Autumn brilliance'	20	15	x		Upright/ round	Mod	Sun/ part. sun	Resistance to ice breakage
Carpinus betulus	Frans Fontain Hornbeam	35	15	x	x	Col	Mod	Sun	
Cercidiphyllum japonicum "Rotfuchs"	Red Fox Katsura	30	16	x	x	Oval	Mod	Sun	
Fagus sylvatica	Red Obelisk	35	12	x	x	Col	Mod	Sun	
Malus	"Marilee"	24	10	x	x	Cone	Mod	Sun	No fruit. Good power line tree.
Prunus	Mt. St. Helens Plum 'Frankthrees'	20	20	x	x	Round	Mod	Sun	Hardy tree. Good power line tree.
Prunus	Snow Goose Cherry 'Snowgoose'	20	20	x		Upright spreadin g	Mod	Sun	Disease resistant. Good power line tree.
Prunus cerasifera	Flowering Plum 'Krauter Vesuvius'	30	15	x	x	Round	Mod	Sun	
Prunus sargentii	Cherry 'Columnarus'	35	15	x	x	Col	Mod	Sun	Fast grower.
Prunus serrulata	Flowering Cherry 'Amanogowa'	20	6	x	x	Vase	Mod	Sun/ part. sun	Short lived. Good power line tree.
Prunus x hillieri	Cherry 'Spire'	30	10	x	x	Col	Mod	Sun/ part. sun	Good fall colors.
Prunus x yedoensis	Flowering Cherry 'Akebono'	25	25	x		Round/ vase	Mod	Sun	Best pick for region. Good power line tree.
Pyrus calleryana	Pear 'Redspire'	35	25	x	x	Pyramid	Mod	Sun	Susceptible to fire blight
Pyrus calleryana	Pear 'Autumn Blaze'	30	25	x		Round	Mod	Sun	Susceptible to fire blight
Tilia americana	Linden 'Redmond'	35	20	x	x	Pyramid	Mod	Sun/ part. sun	tolerant to wet soil
Tilia cordata	Linden 'DeGroot'	30	20	x	x	Pyramid	Mod	Sun/ part. sun	
Tilia cordata	Chancelor Linden 'Chancole'	35	20	x	x	Pyramid	Mod	Sun/ part. sun	Good street tree
Carpinus betulus	Pyramidal European Hornbeam 'Fastigiata'	35	25	x	x	Col	Low	Sun/ part. sun	Very urban tolerant, good street tree

### 10.09.03 Ground Cover Planting

**Table 10-7B** provides several acceptable species of ground covers and, shrubs less than 3 feet high. Many other types of plants may be appropriate and alternative selections may be proposed if desired. Alternative plant choices must be evaluated and approved by the City. The SWMM (Ecology Stormwater Management Manual, Volume 5, Table V-9.4.5) shall be utilized to select groundcover plantings within the wet areas of bio-retention facilities.

Groundcover shall be planted from either four-inch pot with 12-inch spacing or one-gallon pot with 18-inch spacing. Alternative spacing of particular species may be approved by the City if documentation concerning the effectiveness of the groundcover is submitted with the landscape plan.

Table 10-7B Ground Cover						
Botanical Name	Common Name	Mature Height (ft.)	Can be utilized in: M (Medians), L (Landscape Strips)	Minimum Planting Area Width (ft.)	Sun/ Moisture	Obvious Flowers
Arctostaphylos Una-Ursi	Kinnikinnick Bearberry	0.5 to 1	M, L	5 to 6'	Full sun to partial shade	Yes
Ceanothus Gloriosus	California Wild Lilac	1.5	M	6' to 8'	Full sun	Yes
Cotoneaster Dammeri	Bearberry Cotoneaster	< 2	M	5 to 6'		Yes
Euonymus Fortunei Coloratus	Purple Leaf Winter Creeper	1.5	M	6' to 8'	Full sun to light shade	Yes
Juniperus Horizontalis	Blue Chip Juniper/Hughes Juniper	1	M	6' to 8'	Full sun	No
Microbiota Decussata	Siberian Carpet Cypress	1.5	M	7' to 8'	Full sun to light shade	No
Rubus Calycinoides	Evergreen Bramble	1	M	6'	Full sun	Yes
Vinca Minor	Periwinkle	0.5	M	1.5'	Full sun to partial shade	Yes

Table 10-7B Ground Cover (Continued)						
Botanical Name	Common Name	Mature Height (ft.)	Can be utilized in: M (Medians), L (Landscape Strips)	Minimum Planting Area Width (ft.)	Sun/ Moisture	Obvious Flowers
Aucuba	Mr. Goldstrike	8	M	7	Part to Full Sun, Moderate Moisture	Yes
Thymus Serpyllum	Mother of Thyme	0.25	M	1	Full Sun, Drought Tolerant	Yes
Prunus Lavrocerasus	Otto Lyuken	3	M	6	Full to Part Shade, Needs well drained soil	No
Berberus Thungerii	Japanese Barberry	4	M	5	Full Sun, Low Water	N
Phorium	Wings of Gold	3 – 4	M	3	Sun or Shade	N

#### 10.09.04 Planting Methods and Maintenance

Good horticultural practice shall be employed in the preparation of the soil and planting pits. This will include:

1. Conserving topsoil and replacing it on the site.
2. Performing soil tests.
3. Providing corrective soil preparation as necessary.
4. Ensuring landscaping has adequate bedding and base material (minimum 8 inch deep amended soils over minimum 4 inch layer of scarified/tilled base soils all free of rocks, construction debris, slurry, and other construction material)

#### 10.09.05 Establishment Period

The applicant shall be responsible for maintaining the trees and plants in the public landscape strip, medians and entry features in a healthy condition for 1 year after acceptance of the project. For landscape strips that do not include irrigation, maintenance will include providing water during dry periods. Weeds, diseases, and insect pests must also be controlled.

#### 10.09.06 Irrigation Systems

Irrigation systems in the public right of way shall conform to Auburn City Code 12.12.236 and shall adhere to the standards specified in the City of Auburn Construction Standards.

## 10.10 Mailboxes

See City of Auburn Standard Details T-07 thru T-09.

Locating and installing mailboxes in connection with the construction or reconstruction of a City street shall follow AASHTO and Post Office guidelines.

### 10.10.01 Mailbox Locations

Mailboxes shall be located a minimum of 2 feet back from the face of curb on streets which have a curb. For streets without a curb, setbacks shall be determined using ASSHTO standards. When locating mailboxes, access, sight distance, and landscaping requirements shall be taken into account. Final locations shall be detailed on the civil plans and approved by the serving Post Office and the City.

When mailboxes are located in the sidewalk, individually or in clusters, sidewalks shall be widened to provide a minimum 5 feet of clearance around the mailboxes. Widening of the sidewalk may require the dedication of additional right-of way.

### 10.10.02 Mailbox Installation

The owners or residents served by mailboxes will install and thereafter maintain their own individual, clustered, or separated mailboxes as instructed by the U.S. Postal Service.

## 10.11 Illumination

### 10.11.01 General

Roadway lighting is required along all City owned streets except classified Rustic Collectors and Rustic Residential Collectors where only the intersections require lighting. Street lighting design shall be in conformance with the design criteria in the most recent edition of the IES Lighting Handbook (Illuminating Engineering Society of North America) and applicable WSDOT and City of Auburn Design and Construction Standards.

### 10.11.02 Design

**All City street light luminaires shall be LED per City of Auburn Standard Detail T-37.**

**Table 10-8** has been included as a general guideline for determining illumination sizing and location requirements. Street light standards shall be staggered from one side of the roadway to the other, except where site constraints make single sided lighting more feasible and equally effective. The Applicant shall provide project specific lighting calculations that demonstrate minimum illumination levels will be met. Light level calculations shall be done ignoring any existing substandard luminaires (PSE lights on wood poles, etc.).

Special consideration shall be given for light levels at crosswalks, curves, conflict points and street ends. Roadway lighting levels also are impacted by the type of pavement surfacing and special consideration shall be given for surfaces like concrete roadways. The locations of street lights shall take into consideration any obstacles which may screen or impede lighting levels such as street trees and awnings. Minimum separation between street trees and street lights shall be 20 feet or ½ the mature tree canopy width, whichever is greater.

Marked crosswalks at traffic signal controlled intersections and sidewalks in the Downtown Urban Corridor (DUC) zone shall be lit to a minimum of 2-foot candles.



### 10.11.03 Lighting Design Schedule

**Table 10-8** provides minimum lighting design criteria, lamp attachment types, heights, davit arm lengths, and typical spacing for various roadway classifications in the City. The schedule is based on typical straight roadway sections with a staggered lighting configuration. Wider road sections, curves, intersections, cul-de-sacs, single sided lighting configurations require additional analysis to determine the spacing, height, and davit arm lengths required to achieve the required lighting levels.

### 10.11.04 Luminaries

See **City of Auburn Standard Detail T-37** for LED lamp attachment part schedule.

Luminaires shall meet the general requirements City of Auburn Engineering Construction Standards. Street and Pedestrian Luminaires shall operate on 240 Volt AC and all luminaires shall be full cutoff. All luminaires shall be provided with wattage labels for positive identification of Lamp (**See Table 10-8**). A maximum of 5% voltage drop across each circuit will be permitted.

**Table 10-8 Lighting Design Criteria**

Street Classification	Lamp Attachment Type (See City of Auburn Standard Detail T-37)	Avg. Light Level (ft-candle)	Max. Uniformity Ratio	Min. Light Level (ft-candle)	Luminaire Mounting Height (ft)	Spacing* (ft)	Davit Arm Length (ft)
Principal Arterial	Type A	1.4	3 To 1	0.2	35**	190	12
Minor Arterial	Type B	0.9	3 To 1	0.2	35	190	12
Minor Arterial w/Center Turn Lane or Median	Type B	0.9	3 To 1	0.2	35	190	12
Non-Residential Collector	Type B	0.9	3 To 1	0.2	35	200	12
Residential Collector	Type D	0.6	3 To 1	0.2	30	175	14
Residential Collector w/Center Turn Lane or Median	Type D	0.6	3 To 1	0.2	30	175	14
Local Non-Residential	Type D	0.6	3 To 1	0.2	35	160	12
Rustic Roads**		N/A	N/A	N/A	N/A	N/A	N/A
Local Residential and Local Residential Alternate	Type F	0.4	6 To 1	0.1	30	185	8

\* Standard spacing is for staggered arrangement on flat, straight, roadway with the City standard cross section. Spacing where these conditions do not apply shall be determined using analytical methods in accordance with the most recent edition of the IES Lighting Handbook (Illuminating Engineering Society of North America). All design inputs besides spacing shall be held to the specifications listed in **Table 10-8**.

\*\* Lighting for rustic roads shall be at intersections only.

### 10.11.05 Light Standards

City street light poles shall be “cobra head” style per City of Auburn **Standard Detail T-19** except for streets within the DUC zone that shall be per City of Auburn **Standard Detail T-28**. An alternate street light may be utilized along local residential streets per City of Auburn **Standard Detail T-29**.

Street light poles with double davit arms may be allowed in medians as long as lateral offset/clear zone and other applicable design criteria are met.

Light Standards handholes shall be four inches by six inches nominal non-flush type in accordance with City of Auburn **Standard Detail T-19 with tamper resistant screws**.

### 10.11.06 Light Standards Foundations

All light poles shall be placed on a foundation. Foundations for light standards shall conform to City of Auburn **Standard Details T-19, T-28, or T-29**.

Luminaire wiring, conduit, and pole placement within street cross sections that have curb, gutter, and sidewalks shall be per City of Auburn **Standard Detail T-18**.

### 10.11.07 Service Cabinet, Foundation, Conduit

See City of Auburn **Standard Detail T-21**.

All new luminaires shall be connected on an electrical circuit that is connected to a power source through a service cabinet. The service cabinet shall be within 50 feet of the Puget Sound Energy (PSE) point of service connection.

Service cabinets shall be installed behind the sidewalk and at locations that do not impede maintenance access. The cabinet shall be located in the center of the system so there are a near equal number of lights being served on separate circuits from each side of the cabinet. The cabinet shall be labeled with “COA Lighting” and service site address.

The number of luminaires per service will be based upon the type of luminaire and the capacity of the service. Testing may be required to determine if additional luminaires may be added to an existing service.

Service cabinets shall be in conformance with the City of Auburn Engineering Construction Standards All new luminaires shall have a 7 pin PCR7 receptacle and come with a Sensus VantagePoint wireless control node.

Street light conduit shall be per the City of Auburn Construction Standards.

### 10.11.08 Junction Boxes

See City of Auburn **Standard Detail T-20**.

- A. Street Junction boxes shall conform to City of Auburn **Standard Detail T-20**. Junction boxes shall be of the type specified on the plans and shall conform to the requirements of **WSDOT Standard Plan J-40.10**. All junction boxes shall be locking.
- B. Type 1 junction boxes shall be located adjacent to the sidewalk within the landscaping strip, if provided, or adjacent to the back of sidewalk if a landscape strip does not exist, or within the shoulder of a non-curbed roadway. Junction boxes remaining or placed within the sidewalk or walking paths shall be non-skid.

## 10.12 Survey Monuments

See City of Auburn **Standard Details T-11 and T-46**

Survey monuments shall be placed or replaced in accordance with WAC 332-120 (Survey Monuments – Removal or Destruction), and RCW 58-09.120 and good practice in land surveying. Monuments are required along the centerline of improvement of all new or reconstructed streets. Monuments shall be placed at intersections, P.C. (points of curvature), and P.T. (points of tangency).

Unless approved otherwise by the City, ground disturbing activities within 25 feet of an existing survey monument requires securing of a permit from the Department of Natural Resources in advance of those activities. All existing survey monuments that are disturbed, lost, or destroyed during construction shall be replaced by a registered land surveyor registered in the State of Washington at the expense of the responsible builder or applicant. Any monument set shall be permanently marked with the certificate number of the Professional Land Surveyor setting it (which shall be the same Professional Land Surveyor that prepares and certifies the associated monument recording information).

## 10.13 Guardrail

Evaluation of embankments for guardrail installations shall be in accordance with the WSDOT Design Manual.

Guardrail installations shall conform to **WSDOT Standard Plan C-1**, Beam Guardrail Type 1. End anchors shall conform to **WSDOT Standard Plan C-6**, Beam Guardrail Anchor Type 1.

## 10.14 Bollards

See City of Auburn **Standard Detail T-03**.

When necessary to deny vehicle access to an easement, tract, or trail (except for maintenance or emergency vehicles) the point of access shall be closed by a line of bollards. These shall include one or more fixed bollards on each side of the traveled way and removable, locking bollards across the traveled way. Spacing shall provide one bollard on centerline of the trail and other bollards at a maximum spacing of 3 feet to preclude vehicular access. Bollard design shall be in conformance with City of Auburn **Standard Detail T-03**. Fire access roads shall not be blocked in this manner without the concurrence of the Fire Marshal. Bollards are considered fixed roadside objects and shall meet separation requirements described in **Section 10.17**.

## 10.15 Bus Transit Facilities

This section provides the minimum design standards to be used in the design of bus transit facilities in the City of Auburn. Bus facilities shall be designed, located and installed in cooperation with appropriate operating transit agency.

When determined appropriate by the City Engineer, or requested by a transit service agency, an applicant for new or expanded development is required to consult with King County METRO, Pierce Transit, and/or the Muckleshoot Indian Tribal Transit to determine the practicality of how the site can be served by transit oriented improvements such as bus pullout lanes, bus stops, or other appurtenances.

Bus stops are located, designed and installed as part of a cooperative effort between the City and the operating transit agency. Bus stops are managed as part of a right of way use permit granted by the City to the operating transit agency. In general bus stop location and design decisions should follow the facility design guidelines of the operating transit agency. The King County Metro Transit Planning Office or Pierce County Transit should be contacted for specific design questions.

### **10.15.01 Bus Stops Locations**

In general bus stop location and design decisions should follow the facility design guidelines of the operating transit agency. The following are guidelines that indicate where bus stops are appropriate:

- A. Projected or existing passenger boarding and debarking demand warrant a stop.
- B. Traffic characteristics and street design make the location safe to stop a transit vehicle.
- C. The location meets the facility guidelines and fleet specifications of the operating transit agency.
- D. The stop is required to be accessible to the physically challenged (Americans with Disabilities Act).

### **10.15.02 Bus Stops Features**

In general bus stop location and design decisions should follow the facility design guidelines of the operating transit agency. The following are some guidelines that would indicate what type of treatment would be appropriate by type of bus stop.

- A. Shelters should be installed at bus stops with an existing or estimated 25 or more boarding per day.
- B. Benches should be installed at bus stops with an existing or estimated 15 or more boarding per day.
- C. Trash receptacles should be installed and maintained by the operating transit agency at all bus shelters. A sign should be placed indicating that the shelter stop is maintained by the operating transit agency and giving specific contact information to report problems with the stop including a phone number.
- D. At all bus stops experiencing 15 or more boarding per day trash receptacles may be placed by the City or adopt a spot group and should be maintained by the City or the adopt a stop group.
- E. Information schedules and schedule holders shall be placed at all inbound stops (stops where buses are headed toward a major Central Business District), at all transfer points and at heavily used outbound stops.
- F. Additional bus stop lighting should be provided at locations where lighting levels are determined to be less than 3 foot candles.
- G. The stop should be accessible to the physically challenged (meeting the requirements of the Americans with Disabilities Act).
- H. Bus pullout lanes may be required where bus queuing or staging is required by the transit agencies operations and at the discretion of the City Engineer. The following are guidelines that would indicate pullouts would be appropriate:
  - i. Traffic and passenger boarding and debarking conditions warrant.
  - ii. Traffic flow would be greatly hindered due to in lane stopping.
  - iii. The posted speed limit is in excess of 30 mph.

### **10.15.03 Bus Pullout Lanes**

Bus pullout locations shall meet the following requirements:

- A. Placement of bus pullouts shall be on the far side of signalized intersections and non-signalized intersections immediately following the intersection. Distance between pullouts should not be less than 1,000 feet.
- B. If far side pullouts are not possible, nearside pullouts will be evaluated. Mid-block pullouts are discouraged. If a situation arises where a mid-block bus pullout is the only option, pullouts should be constructed on both sides of a two-way street in a complementary pair.
- C. Maintaining adequate separation between access points, intersections, and bus pullouts can increase the safety and efficiency of both the roadway and the transit service.
- D. When locating a bus pullout consideration shall be given to existing access points and where passengers have safe and direct access to sidewalks, crosswalks, ramps, or other pedestrian facilities. Consideration shall also be given to trip attractors, and activity centers.
- E. Bus pullouts must meet sight distance requirements.
- F. Shall be designed in accordance with the applicable operating transit agency's guidelines.
- G. Designs must follow applicable guidelines of the Americans with Disabilities Act.

## 10.16 Traffic Control Devices

Traffic Control devices are all signs, signals, markings and other devices used to regulate, warn, or guide traffic. All traffic control devices shall meet the requirements of FHWA's latest adopted version of the Manual on Uniform Traffic Control Devices (MUTCD) and the standards herein.

### 10.16.01 Median Islands

Median Islands are raised barriers constructed between opposing lanes of travel. Median Islands are generally restricted to classified roadways and may be required in order to:

1. Control access along a corridor, or
2. Provide a traffic calming element.

Median Islands shall be designed using the same geometric criteria as the street on which they will be constructed. Medians shall also meet the following requirements:

- A. **Median Ends:** Median ends shall be flared at intersections and at breaks to allow for transitioning traffic, ease of street sweeping and shall include signage in accordance with MUTCD requirements.
- B. **Width:** Median islands shall be a minimum face of curb to face of curb width of 9 feet when landscaped and a minimum of 4 feet in width when paved.
- C. **Shy Distance:** 1 foot minimum shy distance shall be maintained from face of median curbs to edge of travel lanes.
- D. **Landscaping/Paving:** Landscaping in medians shall conform to the requirements of **Section 10.08**. Median paving shall be stamped concrete with colors and patterns approved by the City.
- E. **Irrigation:** Landscaped medians shall include irrigation systems.
- F. **Illumination:** Street lights on streets with median islands 8 feet in width and greater shall be located in the medians using dual arm posts and shall meet the minimum light level requirements of **Section 10.10**.

- G. **Maintenance Access:** Median islands 8 feet in width and greater shall provide a paved maintenance staging area 50 feet in length with mountable curbs. Median islands smaller than 8 feet in width shall include one 50 foot break in the median per block. All landscaped medians shall provide a 1 foot wide, 6-inch thick, concrete maintenance apron around the perimeter of the median behind the curb.

#### **10.16.02 Mountable Curbs**

Mountable (also referred to as “C” Curbs), are curbs used for the restriction of turning movements and to aid in the channelizing of traffic. Mountable curbs may be required in order to control access along a corridor within the restricted zones of any functional intersection boundary as defined in **Section 10.04**.

Mountable Curbs constructed to retrofit existing roadways shall be constructed per City of Auburn **Standard Detail T-32**. Mountable Curbs constructed on new roadway surfaces shall be cast-in-place curb per **Standard Detail T-47**. All Mountable Curb shall be painted to match the adjacent roadway striping (yellow or white) and shall be marked with raised pavement markers and flexible tubular delineators at the beginning and end sections as shown on City of Auburn **Standard Detail T-32**. Mountable curbs shall be designed to account for roadway drainage.

#### **10.16.03 “Pork Chop” Islands**

“Pork Chop” Islands are barrier islands used to restrict turning movements at driveways. They may be required at any driveway where left turns are restricted and Median Islands or Traffic “C” Curb installation is not feasible. When required, Pork Chops shall be accompanied by appropriate turn restriction signing and pavement markings.

#### **10.16.04 Signage**

All signing shall be per the “Manual on Uniform Traffic Control Devices” (MUTCD) and City of Auburn Engineering Construction Standards.

Developments shall be responsible for providing and installing all traffic control signs, including but not limited to street name signs, regulatory signs, warning signs, barricades, and bicycle/pedestrian signs as required.

Sign posts shall be installed per City of Auburn **Standard Detail T-24**.

Mast arm mounted street name signs shall be per City of Auburn **Standard Detail T-25**.

Post mounted street name signs shall be per City of Auburn **Standard Detail T-26**.

Post mounted “No Parking This Side” signs shall be per City of Auburn **Standard Detail T-40**.

#### **10.16.05 Crosswalks**

Per RCW 46.04.160, crosswalks exist at all roadway intersections, whether marked or un-marked, and regardless of whether there are sidewalks at the intersection. Crosswalks also exist at non-intersection locations where they have been established with crosswalk markings (such as a midblock crossing). For the purposes of these standards, intersections are as defined in Chapter 1 of these standards.

Except within the Downtown Urban Center, crosswalk markings will be per **WSDOT Standard Plan M-15.10**. In the Downtown Urban Center on non-principle arterial streets, crosswalks will conform to City of Auburn **Standard Detail T-43**.

Crosswalks will be marked at the following intersection locations, except where pedestrian facilities are NOT present:

- a. Traffic signal controlled intersections as shown in the figure below:

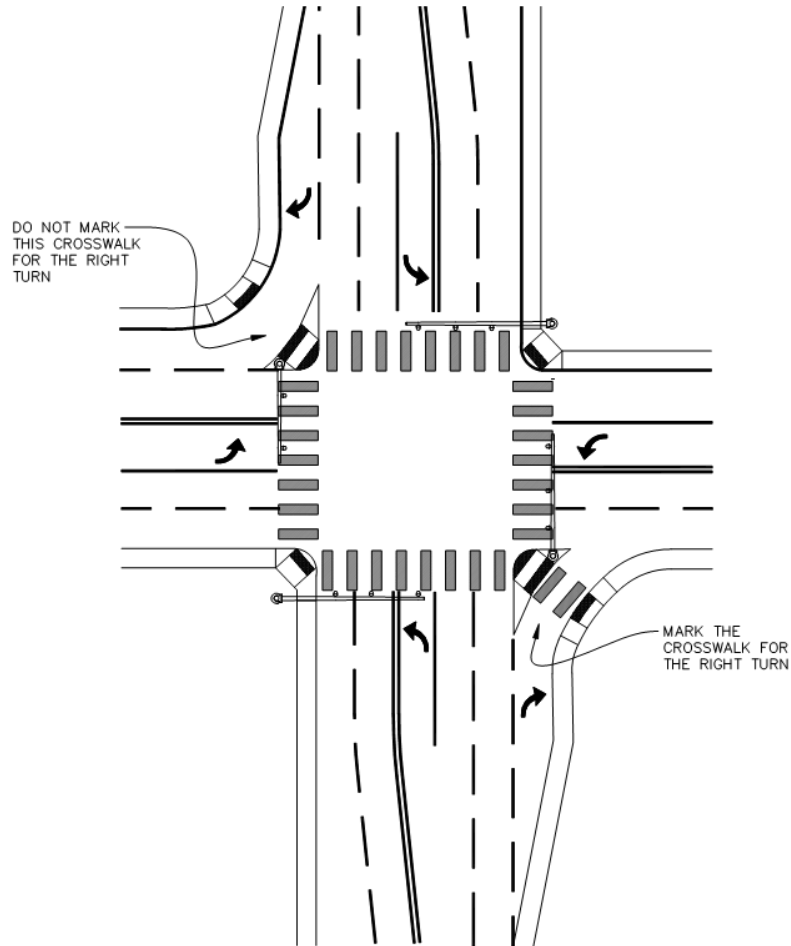

- b. Yield controlled approaches to roundabouts.
- c. Stop controlled approaches at intersections within the Downtown Urban Center.
- d. Stop controlled approaches to Arterial Streets (Principal or Minor Arterials).
- e. Stop controlled approaches at the intersection of two or more arterial and/or collector Streets.
- f. Stop controlled approaches of Local Streets to Non-Residential Collector Streets.

Marked crosswalks at non-intersection locations, and intersection locations not listed above, require enhancement(s) that reduce traffic speeds, shorten crossing distance, increase driver awareness of the crossing and/or provide active warning of pedestrian presence. Selection of appropriate enhancements requires analysis and documentation by an engineer. Enhancements may include, but are not limited to, signage, rapid rectangular flashing beacon(s), and/or bulb-outs.

Permanently closed crosswalks across arterial and collector streets shall have signage indicating that pedestrian crossing is prohibited (**No Pedestrian Crossing Sign, MUTCD R9-3**).

## **10.16.06 Left and Right Turn Lane Channelization**

### **Left-turn Lane Channelization**

**See WSDOT Standard Plans M-3.20 & M-3.40.**

Left-turn lane channelization shall include a minimum of 150 feet of full-width lane. The standard width of a left-turn lane will be 11 feet. Left-turn arrows per **WSDOT Standard Plan M-24.40** shall be installed 25 feet behind the stop bar. Additional storage may be required for long vehicles, anticipated left-turn queues longer than the minimum storage, or to ensure that a left-turn lane is not blocked by an adjacent through queue. If storage length exceeds one hundred 150 feet, auxiliary turn arrows will be installed at 100 foot intervals. Deviation requests from the minimum left-turn lane storage requirements will need a traffic study submittal and approval by the City Engineer.

### **Left-turn Lane at End of Two-way Left-turn Lane**

**See WSDOT Standard Plan M-3.40.**

Left-turn lane at the end of two-way left-turn lanes shall conform to **WSDOT Standard Plan M-3.40.**

### **Dual Left Turn**

**See WSDOT Standard Plan M-3.50.**

### **Right-turn Lane Channelization**

**See WSDOT Standard Plan M-5.10**

Right-turn lane pocket channelization shall include a minimum of 150 feet of full-width lane. The standard width of a right-turn lane will be 11 feet. Additional storage may be required for long vehicles, to accommodate anticipated right-turn queues longer than the minimum storage, or to ensure that a right-turn lane is not blocked by a through queue. Deviation requests from the minimum right-turn lane storage requirements will need a traffic study submittal and approval by the City Engineer. Right-turn arrows per **WSDOT Standard Plan M-5.10.**

“ONLY” lettering per WSDOT 80.10 is required where a through lane converts to a turn lane and other circumstances as determined by the City Engineer.

## **10.16.07 Lane Division**

**See WSDOT Standard Plan M-20.10 and City of Auburn Standard Detail T-12.**

All pavement markings used to separate or channelize traffic shall conform to the referenced Standard Plans and to the City of Auburn Construction Standards.

## **10.16.08 Painted Islands**

Painted islands will be allowed on a case-by-case basis with approval from the City Engineer. Pavement markings for painted islands shall meet the MUTCD requirements.

## **10.16.09 Two-way Left-turn Lanes**

**See WSDOT Standard Plans M-3.20 & M-3.40**



The installation of two-way left-turn lanes on City streets will be determined by the City based on street classifications and left turn requirements. The minimum width of a two-way left-turn lane shall be 11 feet. The delineation lines shall be SBY (Single Broken Yellow) and a SSY (Single Solid Yellow) along the opposing lanes per the MUTCD. Two-way traffic arrows shall be spaced every 250 feet along this lane with a minimum of one per block. The designer should pay special attention to the beginning and endings of this type of lane and use clearly defined tapers or islands to maintain traffic safety.

#### **10.16.10 Other Pavement Markings**

Railroad crossing marking shall be per the standard symbol shown on **WSDOT Standard Plan M-11.10**.

#### **10.16.11 Construction Area Temporary Traffic Control**

The contractor shall be responsible to provide and maintain all signs, barriers, warning lights, striping, and flag control required for maintaining public safety in construction areas. Traffic control shall be maintained at all times when construction is in progress on all streets, and access points in the construction area.

Construction activities will not be allowed in the public right of way without an approved traffic control plan. Contractor to refer to the Construction Standards for further details.

#### **10.16.12 Roadway Barricades**

Temporary and permanent barricades shall conform to the standards described in Section 6C-8 of the Manual on Uniform Traffic Control Devices (MUTCD).

- A. Type I or Type II barricades may be used when traffic is maintained through an area being constructed/reconstructed.
- B. Type III barricades may be used when streets are closed to traffic. Type III barricades may extend completely across the street (as a fence). Where provision must be made for access of equipment and authorized vehicles, the Type III barricades may be provided with movable sections that can be closed when work is not in progress, or with indirect openings that will discourage public entry. Where job site access is provided through the Type III barricades, the developer or contractor shall assure proper closure at the end of each working day.
- C. Type III barricades shall be used at the end of a local access street terminating abruptly without cul-de-sac bulb or on temporarily stubbed off streets. Each such barricade shall be used together with an end-of-road marker. See **Standard Detail T-45**.

#### **10.16.13 Traffic Signals**

Traffic signals shall be designed and constructed in accordance with **Sections 8-20, 9-29**, and other applicable sections of the Construction Standards. Traffic signal facilities shall utilize video vehicular detection. Induction loops are only allowed where the City Engineer has determined that vehicle detection cameras are not feasible. Wherever existing induction loops are damaged and require replacement, , the City Engineer may require replacement of the loop(s) with a video detection system. . WSDOT Standard Plans shall be utilized except the following elements that shall be per City of Auburn Standard Details:

Traffic Signal Controller and Foundation City of Auburn **Standard Detail T-22**

Telecommunication and Luminaire Electrical Trench City of Auburn **Standard Detail T-23**

In accordance with the City's adopted ADA Transition Plan, modification or expansion of any portion of the electrical systems of a signalized intersection or enhanced crossing requires making all pedestrian pushbutton functions (but not locations) and pedestrian signal heads (as applicable) accessible. Additionally, construction, modification, removal or replacement of any portion of any curb ramp at a signalized intersection or enhanced crossing requires making the pedestrian pushbutton location accessible for that ramp and making the pedestrian pushbutton function accessible for the entire signal or enhanced crossing.

## **10.17 Traffic Impact Analysis**

The City of Auburn has established guidelines for Traffic Impact Analysis that are herein adopted by reference. These guidelines are used to identify capacity and safety concerns, to assist in the evaluation of site design as it relates to traffic engineering issues, and to identify appropriate solutions and mitigation.

To adequately assess a development's traffic impact, the City Engineer may require a Traffic Impact Analysis. The requirement for a Traffic Impact Analysis will be based on the size of the development proposed, existing street and intersection conditions, traffic volumes, accident history, safety considerations, community concerns, and other pertinent factors relating to traffic impacts attributable to the development.

### **10.17.01 When Traffic Impact Analyses are Required**

A traffic impact analysis is required for development activities that create one or more of the following conditions:

- The development could potentially affect an intersection or corridor where an existing level of service is at or below standard.
- The development generates more than 30 PM or AM peak hour trips on a corridor or intersection.
- The development may potentially affect the implementation of the street system as outlined in the Comprehensive Transportation Plan and Six Year Transportation Improvement Program (TIP), or of any other documented transportation project.
- The development proposes a rezone of the subject property.
- The original Traffic Impact Analysis for a future development is outdated due to changes in traffic volumes in the vicinity of the proposed project or approved pipeline projects or a change in the proposed land use's trip generation and/or distribution.
- The development could potentially affect safety or requires an analysis to assist in designing appropriate access.

### **10.17.02 Elements of a Traffic Impact Analysis**

Each development traffic review is different and, as such, each traffic study should be cooperatively designed to address the city's specific concerns. Traffic impact analyses are therefore required to be scoped by and with the City Engineer or designee. They may include all or some of the following elements:

- Corridor level of service analyses,
- Intersection level of service analyses,
- Access point level of service analyses,

- Queue Analysis,
- Critical gap analyses,
- Horizontal and vertical sight distance analyses,
- Roundabout analyses,
- Traffic signal warrant analyses,
- Stop control warrant analyses,
- Turn lane warrant analyses,
- Access management design,
- Other analyses and information as required by the City Engineer.

### **10.17.03 Special Uses**

Special event land uses which do not exhibit typical trip generation characteristics may require unique analysis, including but not limited to weekend and off-peak scenarios, and AM versus PM time frames. Examples of such uses would be concert stadiums, racetracks or uses which exhibit substantial traffic peaking associated with special events that are scheduled on a periodic basis.

The traffic analysis for such uses may include a traffic management plan to control traffic impacts associated with the special events.

### **10.17.04 Mitigation Identification**

In order to protect the public from potentially adverse impacts of the proposal, to fulfill an identified need for public services within the impacted area related to the development, or both, the Traffic Impact Analysis shall identify methods of mitigating on-site and off-site deficiencies for present and proposed phases of the development. The analysis shall make recommendations for improvements necessary for safe and efficient traffic flow and bicycle, pedestrian, and transit movement and access proportional to the identified impacts. Build-out Year, Long-Range Forecast Year, and project phasing impacts shall be considered. All or some of the following items are to be included in the mitigation identification:

- Methods for mitigating on-site impacts and mitigation recommendations,
- Methods for mitigating off-site impacts and mitigation recommendations,
- Discussion of whether on-site and off-site improvements are justified, reasonably related to, and proportional to the impacts of the proposed development,
- Any requirements or mitigation measures associated with the Area Circulation Plan.

### **10.17.05 Recommendations**

The Traffic Impact Analysis report shall clearly state the mitigation measures recommended by the analysis and shall summarize how the recommended mitigations are proportional to the identified impacts. The recommended street and highway mitigation measures shall be explained in sufficient detail in the analysis to allow them to be understood and evaluated. The recommendation shall also include the following:

- Clear statements of the applicant's recommended mitigation measures.

- Scaled drawings depicting recommended mitigation improvements and their relationship to existing and proposed conditions if drawings are needed.

### 10.17.06 Area Circulation Plan

Area Circulation Plans are plans which support the development of a multi-modal transportation network with safe, efficient and pleasant routes for pedestrians, bicyclists, transit users, and motor vehicle occupants. The plan recognizes the link between land use and transportation planning and promotes land use and development patterns that encourage walking, bicycling, and transit use.

The goal of an Area Circulation Plan is to "provide a transportation system that will facilitate the safe and efficient movement of people and goods throughout the community while supporting the designated Land Uses in the Comprehensive Plan." This goal applies to all aspects of circulation including: vehicular, mass transit, bicycle, and pedestrian. In order for the City of Auburn to successfully meet the vision set forth in the Comprehensive Plan, the Area Circulation Plan will need to address a variety of transportation modes to facilitate the convenient and efficient movement of people in and near new development.

Area Circulation Plans are required for all new development of general commercial and industrial property. They also may be required for land uses which do not exhibit typical trip generation characteristics that require unique analysis, including but not limited to weekend and off-peak scenarios, and AM versus PM time frames.

The Area Circulation Plan shall include sufficient information to adequately assess the functionality of the proposed development and its impact on surrounding properties and circulation systems, including but not limited to:

- Mapping details, such as site boundaries and dimensions, site acreage, vicinity map, north arrow, scale, title block, etc.;
- Access to the site and interior site circulation;
- Proposed lot layout;
- Other items which may impact adjacent property, such as general parking arrangement, delivery truck/dock locations, medians or traffic control devices, median breaks, and other information as deemed necessary by the City Engineer and Planning Director.

Any development or subdivision of the property shall generally be consistent with the Area Circulation Plan as approved or amended. No plat, building permit, or certificate of occupancy shall be issued for the property unless all construction and development generally conforms to the Area Circulation Plan.

### 10.18 Clear Zone – Lateral Separation

The following standards apply to all new or replaced facilities and do not obligate the City to retrofit or replace existing facilities for the sole purpose of meeting the standards below.

The City has adopted 4 feet as the minimum lateral separation from the face of curb to fixed objects for streets with vertical curbs within the urban environment. **Utility and traffic signal poles along streets with vertical curbs within the urban environment, as defined in Chapter 10 of the AASHTO Roadside Design Guide require minimum 6 feet lateral separation from edge of vehicular travel way.** Under many conditions, additional lateral separation shall be required to provide adequate clear zone per the AASHTO Roadside Design Guide. These conditions include, but are not limited to: streets without vertical curbs, horizontal curves, proximity to driveways, high design speeds (in excess of 45mph), merge locations, crash history, roadways that are not built per existing City standards, and other conditions as deemed applicable by the City Engineer. Reduced minimum lateral separation

along roadways with design speeds of 35 mph or less is allowed for street trees centered within landscape strips and for mailboxes. Minimum separation from the face of curb to any non-fixed roadside object is 2 feet.

**Table 10-1 Summary Matrix of Minimum Street Geometry Design Requirements**

DESIGN CRITERIA	ROADWAY CLASSIFICATION/CATEGORY												
	PRINCIPAL ARTERIAL			MINOR* ARTERIAL		RESIDENTIAL* COLLECTOR	NON-RESIDENTIAL COLLECTOR	RUSTIC COLLECTOR			LOCAL RESIDENTIAL**	LOCAL NON-RESIDENTIAL	RUSTIC RESIDENTIAL
Average Daily Traffic (ADT)	Over 15,000			10,000 – 15,000		2,500 – 10,000	2,500 – 5,000	1,000 – 5,000			Up to 1,200	Up to 1,200	Up to 1,000
Posted Speed (mph) <sup>2</sup>	45	40	35	35	30	30	30	40	35	30	25	30	25
Roadway Cross Section and Additional Criteria, See Listed Figure	Figure 10-01			Figure 10-02		Figure 10-03	Figure 10-04	Figure 10-05			Figure 10-06	Figure 10-07	Figure 10-08
Intersection Curb Radii (ft.) <sup>1</sup>	40 <sup>6</sup>			35 <sup>6</sup>		25 <sup>6</sup>	30 <sup>6</sup>	30			20	30 <sup>6</sup>	20
Intersection ROW Radii- Min. (ft.)	29.5			24.5		14.5	19.5	17			9	19.5	7
Min/Max Horizontal Approach Angle	90° ± 5°			90° ± 5°		90° ± 5°	90° ± 5°	90° ± 5°			90° ± 5°	90° ± 5°	90° ± 5°
Minimum Landing Approach Length (ft.)	30			30		20	20	20			20	20	20
Maximum Landing Approach Grade (%)	3			3		5	5	5			5	5	5
Min. Horizontal Curve Radius (ft.) <sup>2,5</sup> (For Standard Cross Section)	9720	8150	4930	1121	821	544	544	1125	821	544	333	510	333
Min. Tangent Between Reverse Curves (ft.) <sup>2</sup>	150			150		150	150	150			100	150	100
Maximum Rate of Superelevation, e (%)	8			8		0	0	8			0	0	0
Max. Vertical Grade (%) <sup>3,4,7</sup>	6			6		8	8	8			8	8	8
Min. Vertical Grade (%)	0.5			0.5		0.5	0.5	0.5			0.5	0.5	0.5
Cross Slope (%)	3			3		3	3	3			2	2	2

<sup>1</sup> At intersections with two different street classifications, use the highest classification for curb radii except at intersections with residential streets where the lowest order street shall be used

<sup>2</sup> Table values are for standard cross sections with a relatively level grade and are for reference only. For accurate design values reference the AASHTO Manual "A Policy on Geometric Design of Highways & Streets."

<sup>3</sup> Vertical curves will be required when the algebraic grade difference is more than 1%.

<sup>4</sup> See Section 10.02 deviation constraints and requirements.

<sup>5</sup> Minimum radii are for streets designed using the recommended cross slopes listed above. Minimum street radii for Arterials and Rustic Collectors may be reduced by superelevating the street section per the requirements above. Horizontal curve radius for local Residential roads may be reduced to 100 feet with approval of the City Engineer where speeds of 20mph or less are justified or approaching cul-de-sac's.

<sup>6</sup> Intersection Curb Radii reduction may be permitted by City Engineer with approved documentation of design vehicle turning accommodation without impacting opposing traffic lanes

<sup>7</sup> For local residential streets, vertical grades may be increased to 10% without deviation when all other geometric design criteria are met.

# 11 City Telecommunication Utility

## 11.00 Preface

The design of City Telecommunications facilities located within City right-of-way shall be in conformance with these standards.

Compliance with these standards does not alleviate the design engineer from using sound professional engineering practices. The design criteria contained herein are the minimum acceptable under standard conditions. Special conditions may require more stringent requirements that will be addressed during the plan review process.

City telecommunications facilities shall be included in the Public Facility Extension Agreement (FAC) between the developer and the City when the Agreement includes street improvements per ACC 12.64.

## 11.01 Design Criteria

The City has established the following minimum requirements to ensure the efficient construction of City telecommunication utilities with the least impact to City transportation and other utility infrastructure. The design of City telecommunications facilities shall also meet the requirements of **Section 9.03.02**, Public and Private Utilities Located Underground Within City Right-of-Way with the exception that a construction permit is not required if this work is completed as part of a Facility Extension Agreement.

City telecommunications facilities may be required in conjunction with street improvements on all roadways classified as Arterial or Collector. Such facilities, when required, shall be extended the full length of the street improvement. When feasible, placement of the facilities shall accommodate connection with other existing or future telecommunication facilities within the corridor.

### 11.01.01 Conduits

City telecommunication conduits shall be 3-inch PVC Schedule 40 and shall have a minimum of 24 inches of cover and, except for street crossings, shall be located under the sidewalk per City of Auburn **Standard Detail T-23**. If no sidewalk is included in the scope of the required street improvements, the conduit will be installed in the most feasible location within the street construction limits as directed by the City. Roadway crossings shall be minimized and sweeps shall be long sweep 90-degree bends. Trace wire shall be placed within the conduit. Conduits shall be placed a minimum of 5 feet from other utilities.

### 11.01.02 Splice Vaults and Pull Boxes

When required, splice vaults and pull boxes shall be per **WSDOT Standard Plans J-90.21 and J-90.10**, respectively, except that lid marking lettering shall be as specified in the Construction Standards and lids shall not be marked with WSDOT logos or text indicating WSDOT. Splice vaults shall be placed every 1,500 feet. Pull boxes shall be placed every 500 feet and at all arterial and collector intersections.